

Loop Powered Scaling Meter

Unit Description

M4NS-NA



1. Display value, parameter, error display
2. M, MD key: When enter into parameter group, return to RUN mode, after completing parameter setting

M4YS-NA

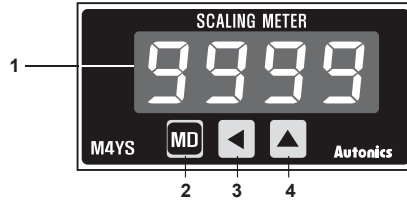

3. ▲, ▲ (Up) key: When enter into the status of parameter setting
4. ▲, ◀ (Shift) key: When enter into the status of parameter setting and move digit

Connections

M4NS-NA

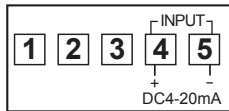

M4YS-NA



Dimensions

M4NS-NA

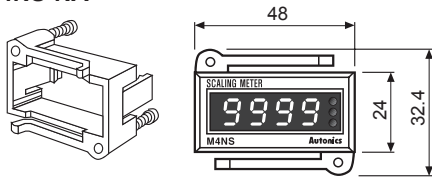

Panel cut-out

(unit: mm)

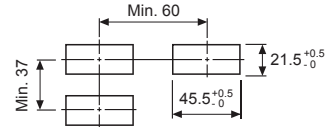

M4YS-NA

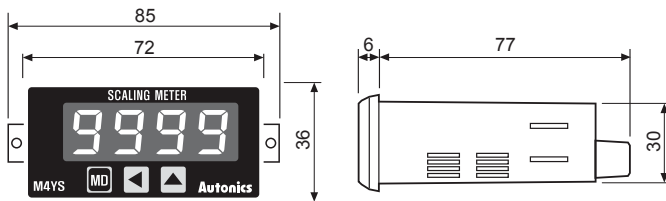

Panel cut-out

(unit: mm)

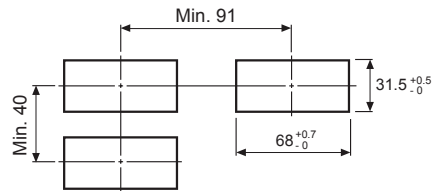

Parameter

Display	Function	Setting range
L - 5C	Low scale Low limit display value for 4mA input	-1.999 to 9.999 -19.99 to 99.99
H - 5C	High scale High limit display value for 20mA input	-199.9 to 999.9 -1999 to 9999
dot	Decimal point Set Decimal point position	0000, 000.0 00.00, 0.000
l n b, l	Input bias low Correct the Low-limit value of display value (Digit)	-100 to 100
l n b, H	Input bias high Correct the High-limit value of display value (%)	0.900 to 1.100
PELT	Peak time See the peak value monitoring delay time	0 to 30sec.
d! 5t	Display time Selectable sampling period (sec)	Selectable 0.5/1.0/ 2.0/3.0/4.0/5.0sec.
EPCt	Error % Set % of HHHH/LLLL display range	0, 1, 2, 3, 4
LoC	Lock Set the lock function	Selectable ON, OFF

Factory default setting

Parameter	Parameter display	Factory default
Low limit display value for 4mA input	L - 5C	0400
Hi limit display value for 20mA input	H - 5C	2000
Set Dot position	dot	00.00
Correction of Low limit value input	l n b, l	0000
Correction of Hi limit value input	l n b, H	1.000
Peak value monitoring delay time	PELT	015
Display cycle	d! 5t	0.55
Set % of HHHH/LLLL display range	EPCt	3
Lock setting	LoC	oFF

- (A) Photoelectric Sensors
- (B) Fiber Optic Sensors
- (C) Door/Area Sensors
- (D) Proximity Sensors
- (E) Pressure Sensors
- (F) Rotary Encoders
- (G) Connectors/ Sockets
- (H) Temperature Controllers
- (I) SSRs / Power Controllers
- (J) Counters
- (K) Timers
- (L) Panel Meters
- (M) Tacho / Speed / Pulse Meters
- (N) Display Units
- (O) Sensor Controllers
- (P) Switching Mode Power Supplies
- (Q) Stepper Motors & Drivers & Controllers
- (R) Graphic/ Logic Panels
- (S) Field Network Devices
- (T) Software

Parameter Group 0 (Monitoring Mode)

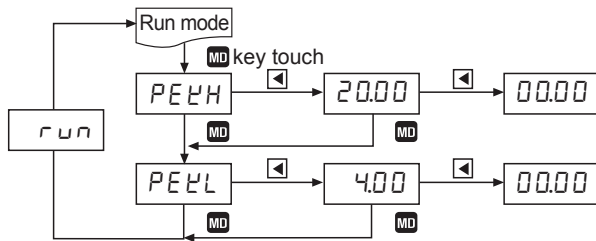

Pressing **MD** key to enter monitoring mode in RUN mode.

Each peak value will be shown by pressing **MD** key in monitoring mode and peak value will be initialized by pressing **MD** key once more.

If no key touched for 60sec., it will return to RUN mode.

※When do not use monitoring function, set 00 5 for PEEL in Parameter setting.

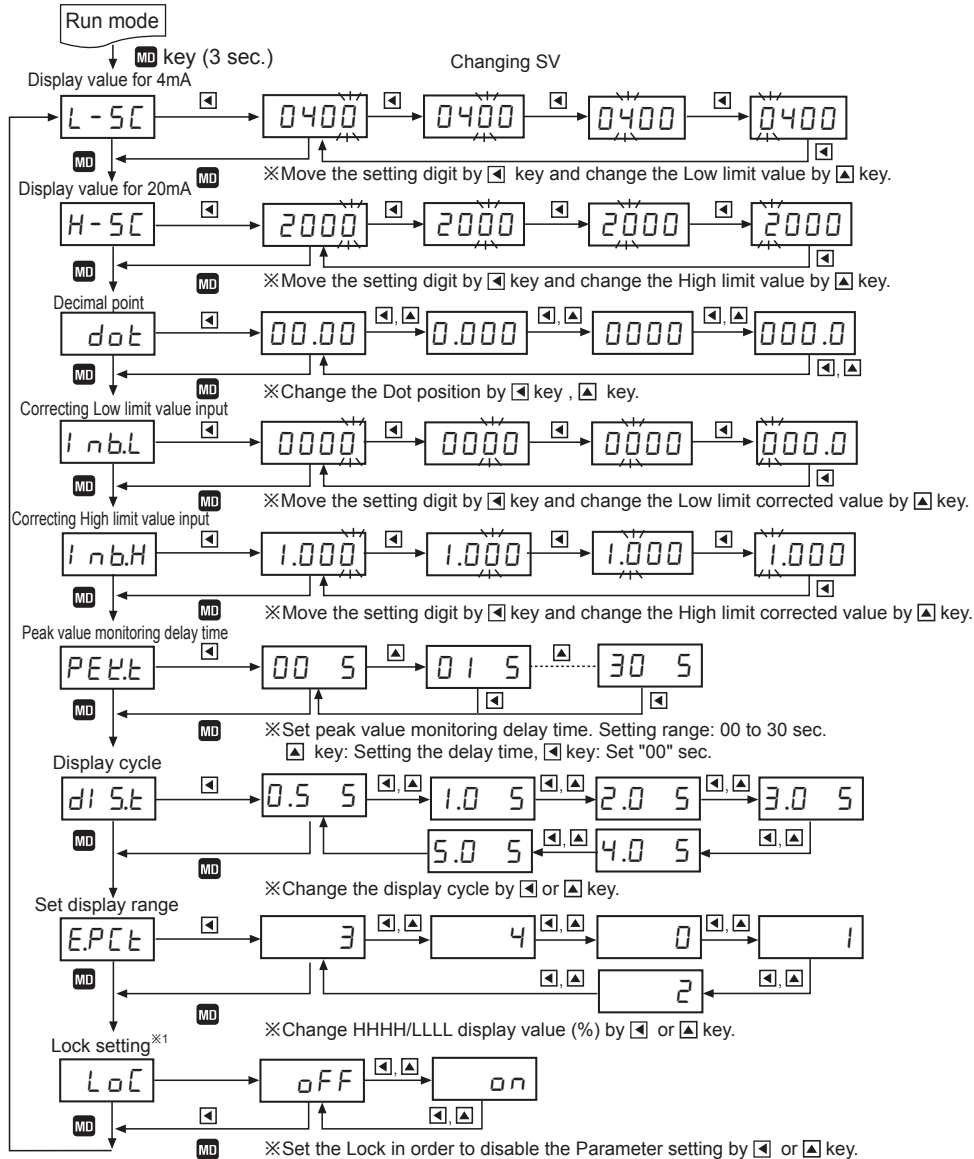

※Press **MD** key to complete the setting and move to next Parameter in status of changing setting value.

※Press **MD** key is pressed for 3 sec. to move to RUN mode after displaying [run]

※If any key is untouched for 60 sec., it will return to RUN mode.

※1: Lock setting [OFF: Enable to change or set Parameter.

[ON: Disable to change or set Parameter but enable to check the setting value in Parameter group.

Disable to enter into the status of change setting value by pressing **MD**, **MD** keys.

Loop Powered Scaling Meter

Application Of Connections

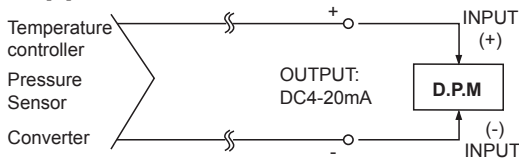

Functions

Display scale [L - 5C / H - 5C]

This function is to display the value setting certain Hi/Low limit value against DC4-20mA input. For example if set a=DC4mA, b=DC20mA and A, B as display value, it will be displayed a=A, b=B.

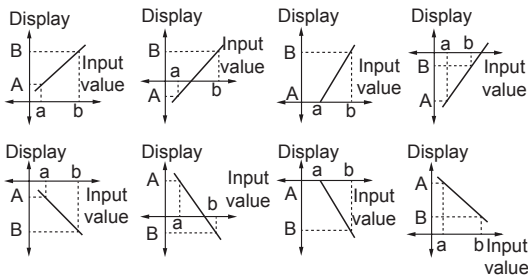

Decimal point setting [dot]

This function is to set the decimal point position of display value (Set in Parameter setting group)



Able to use \leftarrow (Shift) or \uparrow (Up) for moving decimal.

Correction [Inb.H / Inb.L]

This function is to adjust the error of display value after calculating scale value for measuring input and also correct the input error of sensor etc.

Inb.L: -100 to 100 [Adjust deviation of low value]

Inb.H: 0.900 to 1.100 [Correct gradient (%) of high value]

E.g.) When display value is 0.0 to 500.0 against 4-20mA input, if the display value is "1.2" for 4mA input, set -12 (Ignore the decimal point) as Inb.L value to display "0.0". It is enable to remove offset of Low display value.

※ When completed above Low value setting then apply 20mA, if the display value is "500.5, the correction value will be $5005/5000=0.999$, set 0.999 as Inb.H value then enable to correct High value is $50005 \times 0.999 = 5000$. It is also ignore the decimal point.

Display cycle delay

It is difficult to display when the measuring input value is fluctuating. In this case it is able to make display value stable by delaying display cycle. Display cycle can be changed in d1 5t mode of Parameter 2 (Selectable 0.5s/1.0s/2.0s/3.0s/4.0s/5.0s). If select 5.0s, it will be the measuring input value on an average for 5sec., then display it every 5sec.

Error display [E.P.C.E.]

• Error setting and sort

It will display the error message according to the setting value which set % value against analog input range and set it in E.P.C.E mode by \leftarrow , \uparrow key.

Error code	Error description
E.P.C.E.0	LLLL / HHHH are displayed when it is over 0% out DC4-20mA range
E.P.C.E.1	LLLL / HHHH are displayed when it is over 1% out DC4-20mA range
E.P.C.E.2	LLLL / HHHH are displayed when it is over 2% out DC4-20mA range
E.P.C.E.3	LLLL / HHHH are displayed when it is over 3% out DC4-20mA range
E.P.C.E.4	L - 5C / H - 5C are displayed always when it is out of DC4-20mA range

• Error display

① When [LLLL] flashes,

Input current is lower than 3% in 4-20mADC (16mA scale) LLLL will flash when it is under 3.52mA [$16mA \times 3\% = 0.48mA$] $\rightarrow 4mA - 0.48mA = 3.52mA$ When it is beyond Min. display value (-1999) [by display value]

② When [HHHH] flashes,

Input current is higher than 3% in 4-20mADC (16mA scale) HHHH flash [$16mA \times 3\% = 0.48mA$] $\rightarrow 20mA + 0.48mA = 20.48mA$. When it is higher than 20.48mA. When it is beyond Max. display value (9999) [by display value]

• Turn Error display off

LLLL and HHHH are displayed when input is out of measuring range, therefore it will be disappeared automatically when input returns to measuring range.

Display peak value monitoring

[PEEH / PEEL]

This function is to monitor Max. value and Min. value by current display value then display its Data in PEEH mode and PEEL mode.

Enable to set delay time in PEEL mode to protect the wrong Data by initial over current and settable from 0 to 30sec. and start to monitor after delay time.

(A)	Photoelectric Sensors
(B)	Fiber Optic Sensors
(C)	Door/Area Sensors
(D)	Proximity Sensors
(E)	Pressure Sensors
(F)	Rotary Encoders
(G)	Connectors/ Sockets
(H)	Temperature Controllers
(I)	SSRs / Power Controllers
(J)	Counters
(K)	Timers
(L)	Panel Meters
(M)	Tacho / Speed / Pulse Meters
(N)	Display Units
(O)	Sensor Controllers
(P)	Switching Mode Power Supplies
(Q)	Stepper Motors & Drivers & Controllers
(R)	Graphic/ Logic Panels
(S)	Field Network Devices
(T)	Software