

Miniature photoelectric sensor PSV series



Feature description

- Small size, easy to install and use
- With 360° visible bright LED status indicator
- Superior anti-light interference, stable product performance
- Red light source for easy adjustment and alignment



Model specification

NPN NO	PSV-YR30DNOR	PNP NO	PSV-YR30DPOR
NPN NC	PSV-YR30DNCR	PNP NC	PSV-YR30DPCR

Specifications

Detection distance	30mm ^①	Indicator	Green:power,stable indicator;Yellow:output indicator
Dead zone	<4mm	Response time	<1ms
Standard test body	50*50mm white cards	Anti ambient light	Sunlight interference ≤10,000 lux Incandescent light interference ≤3,000 lux
Light spot size	2mm@30mm	Operating temperature	-20...55 °C
Color sensitivity	> 85%	Storage temperature	-30...70 °C
Hysteresis	< 20%	Protection degree	IP65
Supply voltage	10...30V DC	Certification	CE
Consumption current	≤15mA	Shell material	PC+PBT
Load current	≤50mA	Lens	PC
Voltage drop	< 1.5V	Weight	22g
Light source	Red light(680nm)	Accessory	Screws(M2×8mm)×2、Nut×2
Protection circuit	Short circuit protection,Polarity protection Overload protection,Zener protection		

①Use 50*50mm white card with reflectivity greater than 90%

Dimension

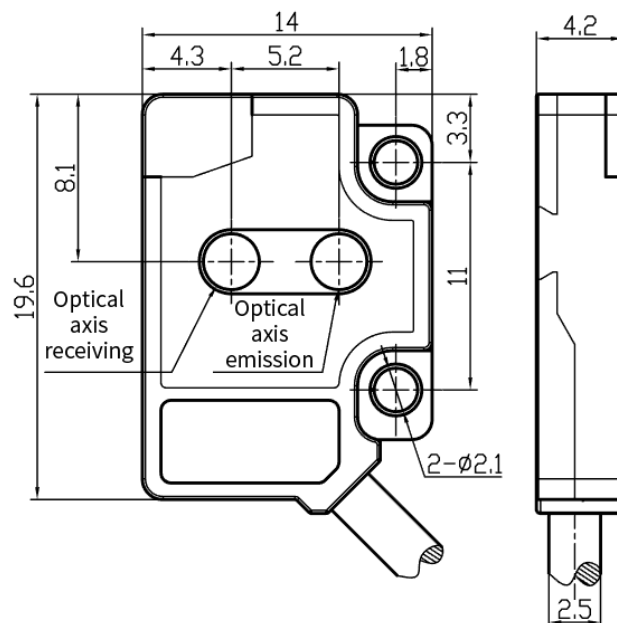

Wiring diagram

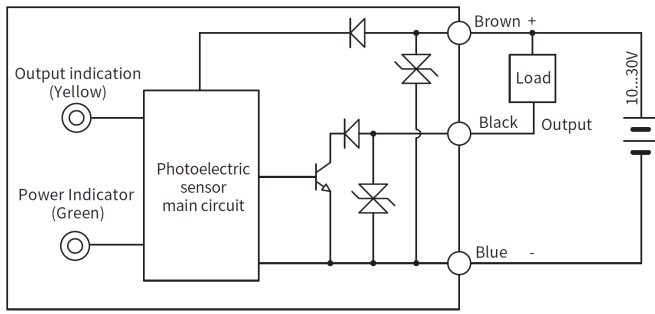

NPN

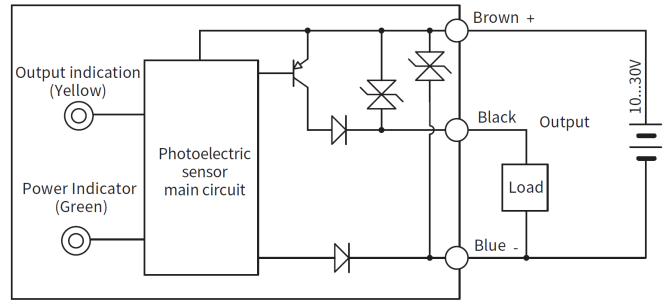

PNP