



Photoelectric sensor

PTL series

Instruction



CE

- Special IC design, with stable performance
- With surge protection, reverse polarity protection and short-circuit protection
- Housing material: PC/ABS
- Protection degree: IP67(IEC)

Model description

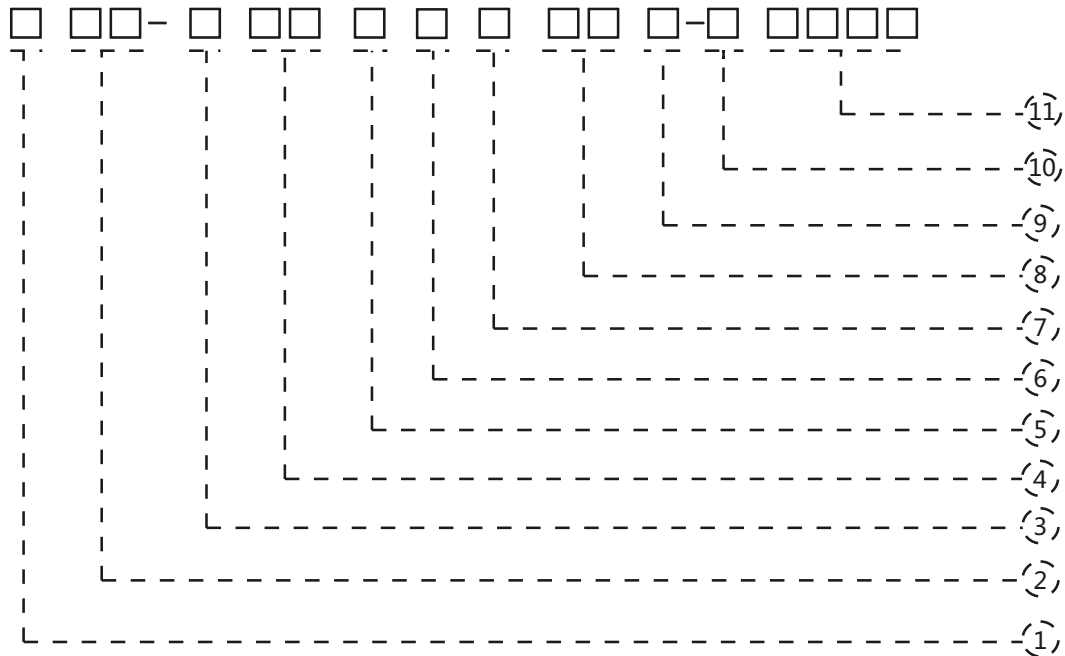

1. Type code

P:Photoelectric

2. Shell code

TL:Rectangular shell

3. Mounting

B:Diffuse reflection
D:Retro reflection
P:with polarizer
T:Through beam

4. Sensing distance

C80:80cm
C200:200cm
M20:20m
M40:40m

5. Operating voltage

D:10...30VDC
S:12...240VDC
/24...240VAC
T:12...24VDC

6. Output mode

P:PNP
N:NPN
K:Relay

7. Output status

O:NO
C:NC
R:NO+NC
Note: Relay output is optional

8 .Delayed status

T3:With before-delayed and after-delayed function

9 .Cable length

3M:3m

10 .Connection

E2:M12 connector (4 pins)
E4:M12 trapezoid connector (4 pins)
E5:M12 connector (5 pins)
D:Terminal

11 .Special Requirements

In 4 digits

Specification parameter

Detection way	Diffuse reflection	Retro reflection
Product model	PTL-BC...-D	PTL-DM...-D
Sensing distance	80cm, 2m	5m
Output	DC : NPN NO+NC PNP NO+NC / AC:Contact output	
Supply voltage	DC : 10...30 VDC±10% / AC : 24...240 VAC±10% 50...60Hz/12...240 VDC±10%	
Light source	Infrared LED(880nm)	
Load current	DC: transistor output < 200mA/AC DC: relay output < 3A	
Voltage drop	DC : <2.5V	
Power consumption	Emitter and receiver < 1.5W / Reflection type < 2W	
Hysteresis range	3...20%	...
Repeat accuracy	< 5%	< 5%
Response time	DC : < 8.2ms/AC : < 30ms	DC : < 8.2ms/AC : < 30ms
Indicator	Operation indicator: Yellow LED	
Circuit protection	Polarity protection, surge protection, short-circuit protection, overload protection	
Ambient temperature	-15...+55°C	
Ambient humidity	35...95%	
Protection degree	IP67	
Housing material	PC/ABS	
Connection	Terminal connection	
Certificate	CE	

Detection way	Through beam	Polarizde reflection
Product model	PTL-TM...-D PTL-TM...-D	PTL-PM...-D
Sensing distance	20m, 30m, 40m	12m
Output	DC : NPN NO+NC PNP NO+NC /AC:Contact output	
Supply voltage	DC : 10...30 VDC±10% / AC : 24...240 VAC±10% 50...60Hz/12...240 VDC±10%	
Light source	Red LED(880nm)	Red LED(660nm)
Load current	DC: transistor output < 200mA/AC DC: relay output < 3A	
Voltage drop	DC : <2.5V	
Power consumption	Emitter and receiver < 1.5W / Reflection type < 2W	
Hysteresis range
Repeat accuracy	< 5%	< 5%
Response time	DC : < 8.2ms/AC : < 30ms	DC : < 8.2ms/AC : < 30ms
Indicator	Operation indicator: Yellow LED	
Circuit protection	Polarity protection, surge protection, short-circuit protection, overload protection	
Ambient temperature	-15...+55°C	
Ambient humidity	35...95%	
Protection degree	IP67	
Housing material	PC/ABS	
Connection	Terminal connection	
Certificate	CE	

Product dimension

Terminal connection

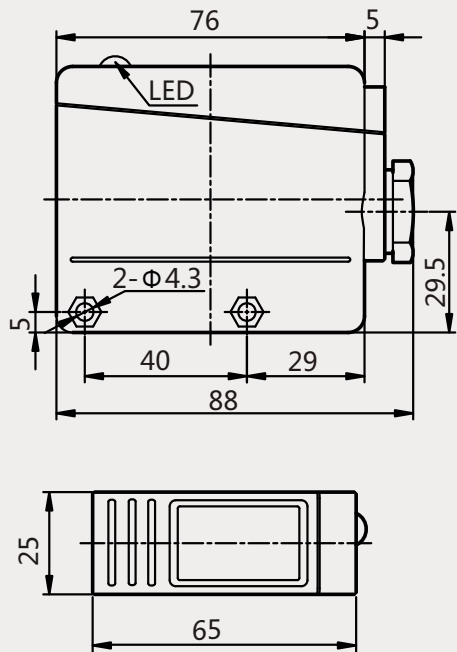

Installation instruction

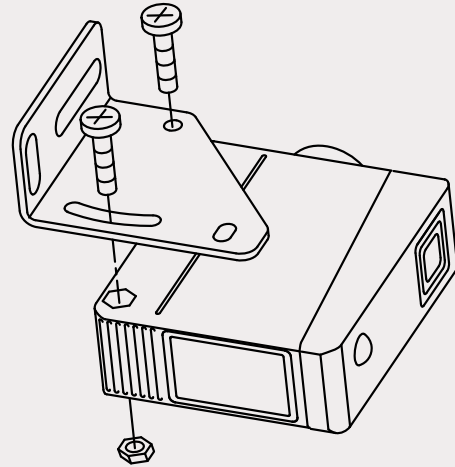

Mounting bracket

ZJP-6

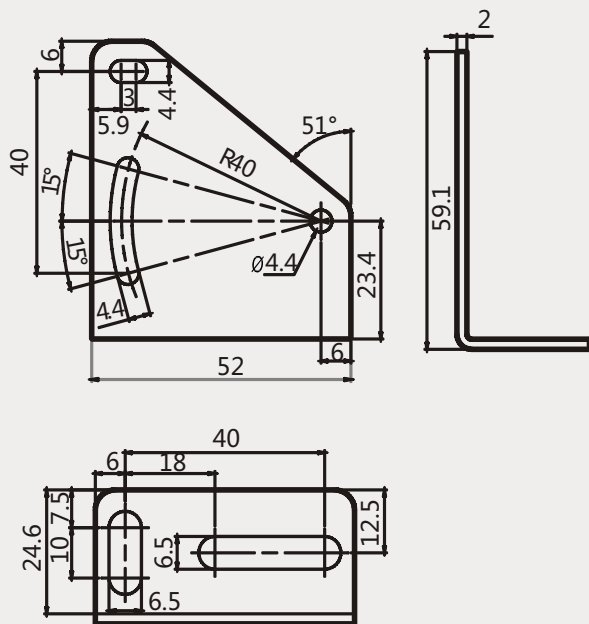

Wiring diagram

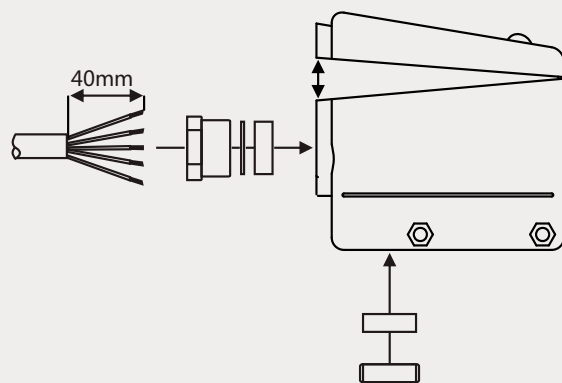

Terminal wiring diagram

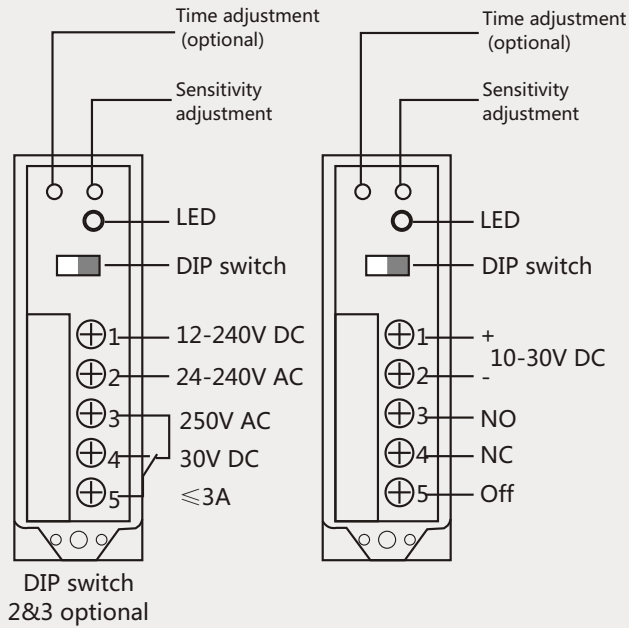

PTL-PM...

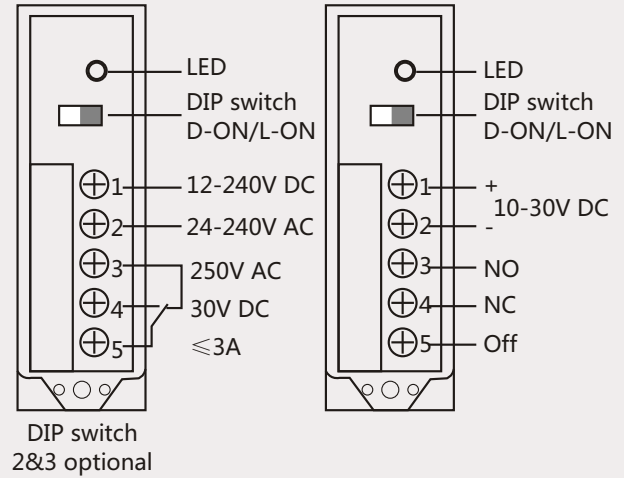

Operation instruction

T=Time delayed tv=Power on delay ☒=Ignore

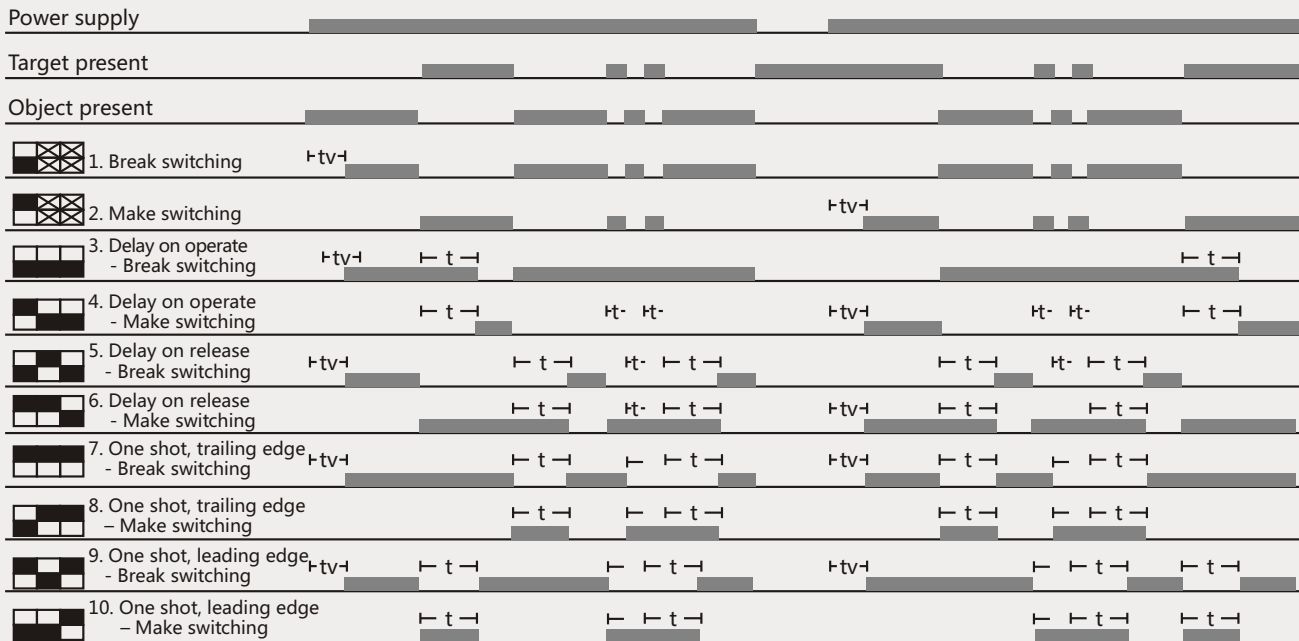

1 2 3 Mode 1: Upper position ON Mode 0: Lower position OFF 3-10: only for the type with timing function
DIP

Output circuit

NPN Output

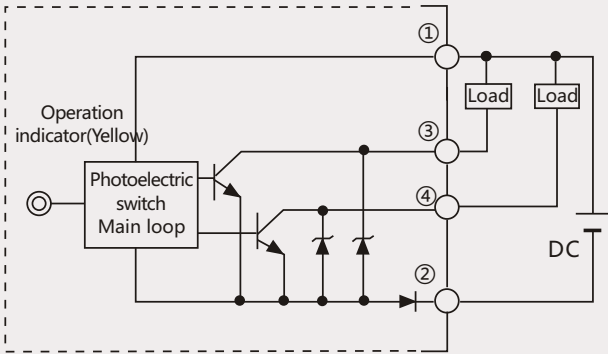

NPN Output

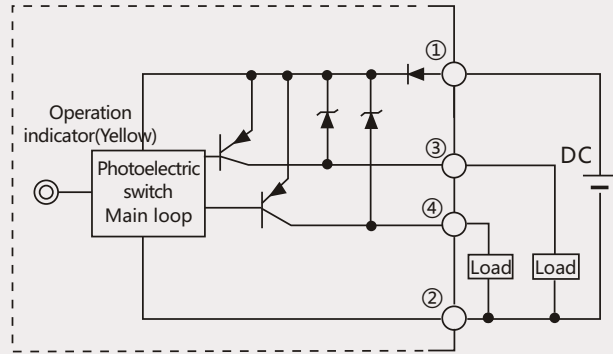

Relay output

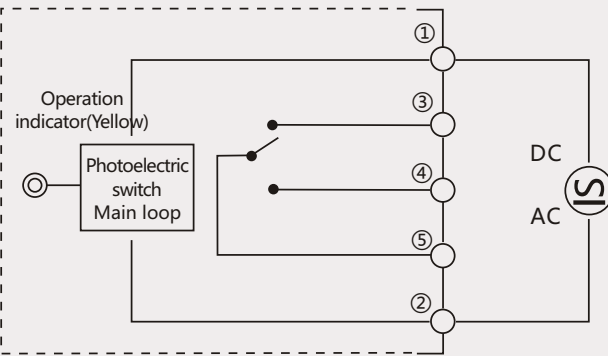

Transmitting terminal of through beam

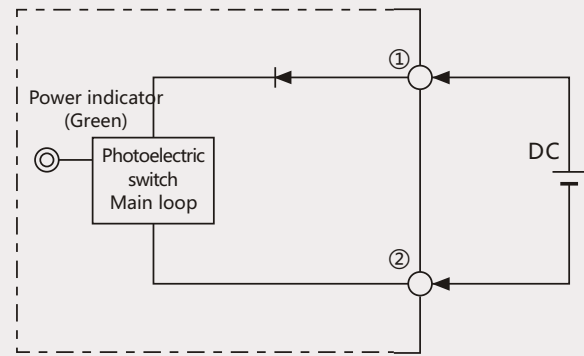

Receiving terminal of through beam

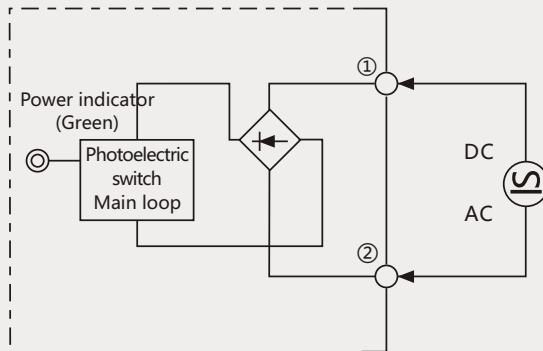

Installation caution

Key points about security

Please be sure to follow the following points, which are very important in security

- Don't use the product in flammable or explosive gas environment
- Don't tear down, repair or transform this product
- Supply voltage must be within rated value
(10...30 VDC \pm 10%/24...240 VAC \pm 10% 50...60Hz/12...240 VDC \pm 10%).
- Please use load within rated value.

Application method

Proper usage

1. Don't use the product in the following environment:

- Place with direct sunlight
- Place with high humidity and dew
- Place with corrosive gas
- Place with vibration and striking energy

2. Connection and installation

- Maximum allowable voltage is 10% of rated voltage. Please make sure the power supply is lower than the maximum value before power on.
- In principle, sensor cable must be placed separately or conductively-closed, or sensor will be disturbed or even damaged.
- To lengthen the cable, section must be over 0.3mm² and wire be less than 100m
- Don't pull the wire too hard.
- Avoid violent force onto sensors during installation as it may damage the performance of sensors. Please fix it with standard bolt when installing.

⊙ About terminal connection:

- Connect the terminal when the power is cut off.
- Please hold the shell of sensor when connecting.
- Please be sure to use hand to fix, because pliers may damage the product
- Appropriate torque is 0.3~0.4N•m, if the torque is not enough, then it may lose protection function after vibration.
- The appearance of cable should be over Φ 5.2mm for better sealing performance.

3. Cleaning

- Please avoid using diluents which may melt product appearance.

4. Power supply

- Please connect FG (Frame Ground) to the ground when using switching rectifier

5. Readjust the time of power

- Please use the sensor after 100ms 's energization, because the time from power on to normal sensing is 100ms. If load and sensor use different powers, then please power on sensor first

6. Power off

- When power is turned off, it may appear output pulse; it is recommended closing the power of load or load wire first.

7. Load short-circuit protection

- The sensor with DC operation has short-circuit protection, the output will become OFF when load short circuit happens, so please connect the power after amending the circuit. Furthermore, protection function will be triggered if load current in circuit is over 1.8 time of rated value. Please be sure the current in circuit should be lower than rated load current when connecting load.

8. Waterproof

- Even the waterproof degree is IP67; it is better not using the product in water, rain, or outdoors.

Commitment

Attentions

- For security reason, please do not use this product for human body detection, when there is need to detect body, please select safety sensors published in our product summary.
- Please contact our customer service department and confirm the specification first to make sure safety in case of below special applications:
 - ① Used in outdoors, potential chemical pollution environment, or the environment which have never recorded in product manual or operation instruction.
 - ② Used in atomic energy control device, incineration equipment, railway, aviation, vehicle equipment, medical equipment, entertainment equipment, safety device or any other special defined manufacturing devices etc.
 - ③ Used in system or device which may threat human life or property.
 - ④ Used in gas, waterway or electric power supply system, or high-reliability device which runs 24 hours a day.
 - ⑤ Used in application which needs high-security.