

Plastic square photoelectric sensor PSE-GC series



Feature description

- Universal housing, an ideal substitute for sensors of various styles
- Comply with IP67, suitable for harsh environment
- Sensitivity one-key setting, accurate and fast setting
- Stable detection of various transparent bottles and various transparent films
- Normally open and normally closed switchable
- Coaxial optical principle, no blind zone



Model specification

NPN NO/NC	PSE-GC50DNBB	PNP NO/NC	PSE-GC50DPBB
-----------	--------------	-----------	--------------

Specifications

Detection distance	50cm	Operating temperature	- 25...55 °C (No condensation, no icing)
Light spot size	≤14mm@0.5m	Vibration resistance	10...55Hz, Double amplitude 0.5mm (2.5hrs each for X、Y、Z direction)
Supply voltage	10...30VDC (Ripple P-P: < 10%)	Impulse withstand	500m/s ² , 3 times each for X、Y、Z direction
Consumption current	< 25mA	High pressure resistant	1000V/AC 50/60Hz 60s
Load current	200mA	Protection degree	IP67
Voltage drop	≤1.5V	Certification	CE
Light source	Blue light(460nm)	Housing material	PC+ABS
Protection circuit	Short circuit protection, Polarity protection, Overload protection	Lens	PMMA
Indicator	Green:Power indicator Yellow:Output indication, Overload indication	Weight	10g
Response time	< 0.5ms	Connection type	2m PVC Cable
Anti ambient light	Sunshine ≤10,000Lux; Incandescent ≤3,000Lux	Accessories	Mounting Bracket:ZJP-8, Operation manual, TD-08 Reflector
Storage temperature	- 30...70 °C		
NO/NC adjustment	Press the button for 5...8s, when the yellow and green light flash synchronously at 2Hz, finish the state switching.		
Distance adjustment	The product is facing the reflector, press the button for 2...5s, when the yellow and green light flash synchronously at 4Hz, and lift to finish the distance setting. If the yellow and green light flash asynchronously at 8Hz, setting fails and the product distance goes to the maximum.		

Dimension

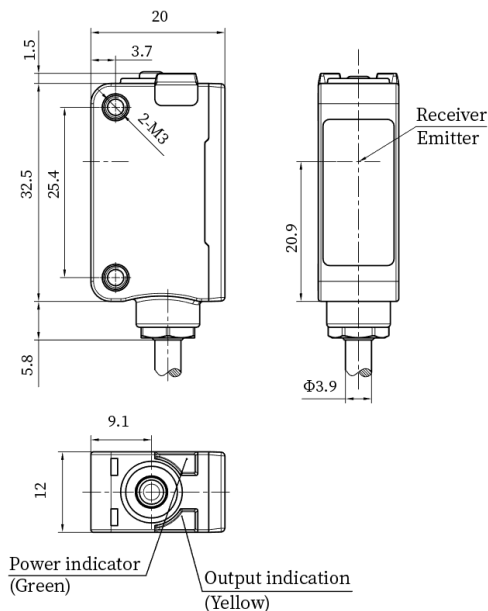

Wiring diagram

