

Miniature photoelectric sensor PST series



Shanghai Lanbao Sensing Technology Co., Ltd.

Miniature photoelectric sensor

PST series

Product advantages

➤ Accurate and fast

- Quick response and positioning
- Laser-like light spot, high precision positioning
- Integrated chip design, strong resistance to light interference

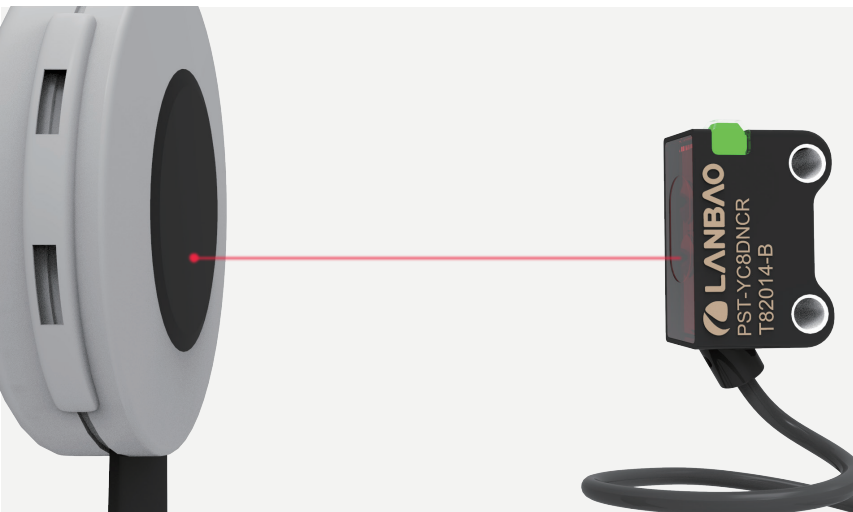

➤ Easy application

- Tiny and exquisite, easy to install
- Highlight 360°LED indicator, highly effective detection
- IP67 protection degree, strong protection
- 45° cable, space-saving
- Stainless steel embedded, high strength
- Standard industrial installation design, simpler installation
- Complete specifications, various applications



Miniature photoelectric sensor PST background suppression series

Product unique advantages

- Distinguishable for multiple colors
- Multi-turn accurate distance
- Multi-turn accurate distance

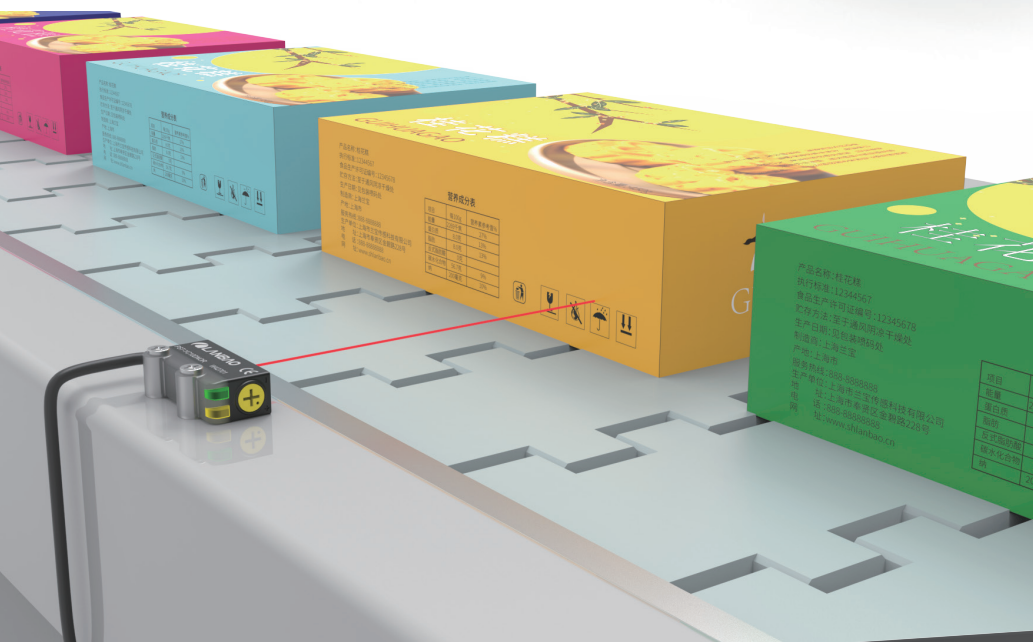
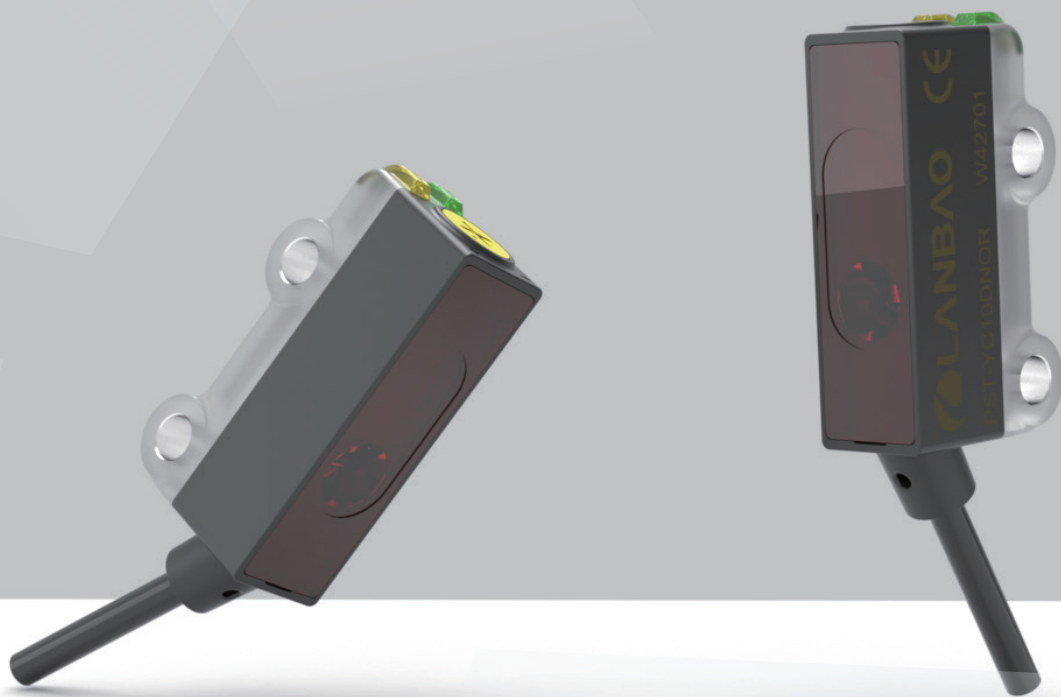

- Excellent optical structure design
- Excellent optical structure design

Multi-turn potentiometer design, accurate distance adjustment



Applications

Bottle cap detection

The background suppression series can stably detect beer bottle caps with its laser-like light spot and excellent black and white color difference characteristics.

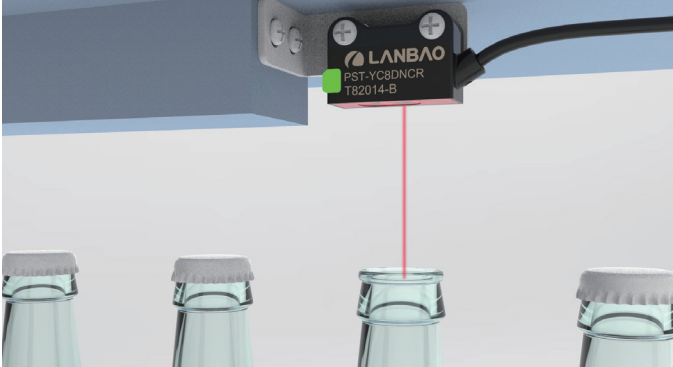

Copper wire detection

Convergent reflection series are able to detect $\phi 0.1\text{mm}$ copper wire, highly fit for tiny objects detection.

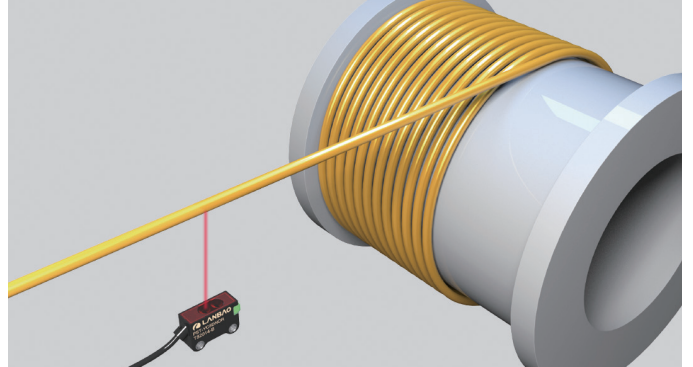

Silicone wafer detection

The background suppression series can achieve stable detection of extremely black trays or silicon wafers thanks to its excellent black-white difference characteristics.

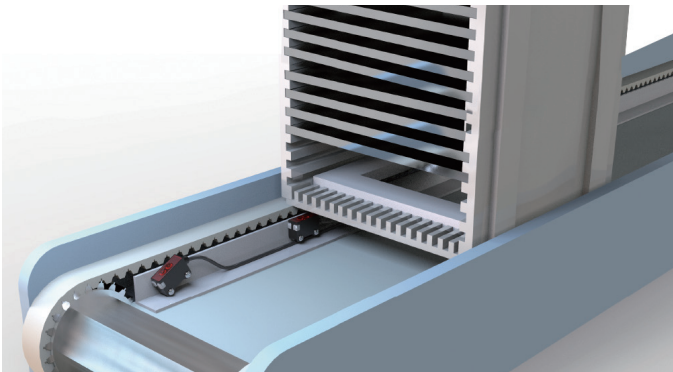

Chip detection

Through beam series is red light spot design, enabling the detection and counting function of the small chips.

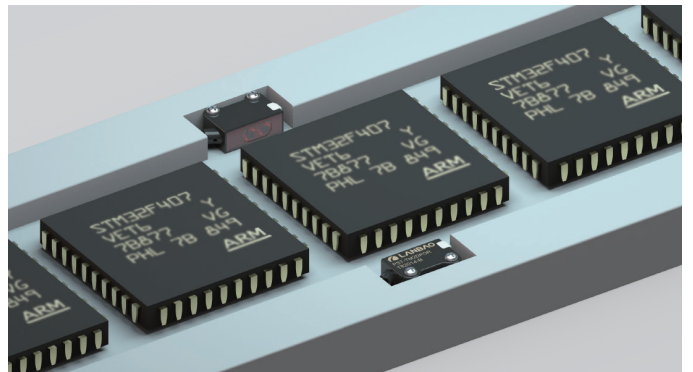

Workpiece detection

Tiny black-white difference, suitable for changeable colors detection.

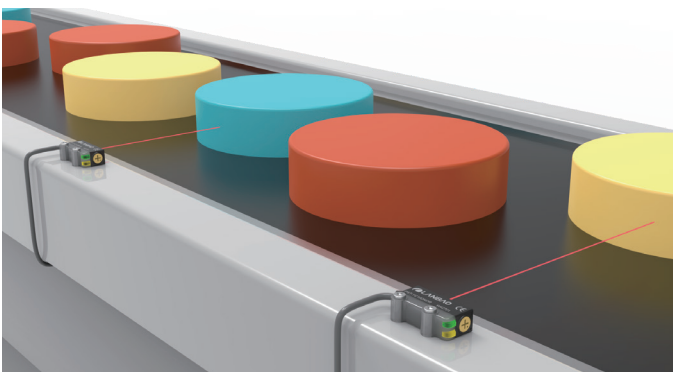

Silicon detection

Adoption of laser-like spot design with high luminous intensity. Realization of extremely black silicon wafer detection.

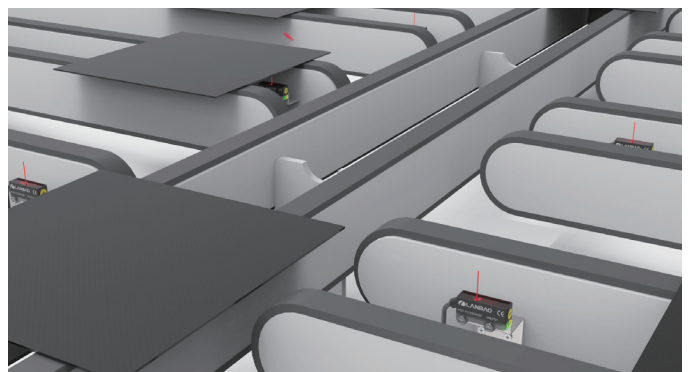

Guide Selection

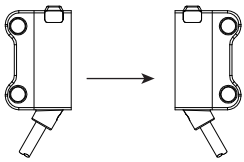
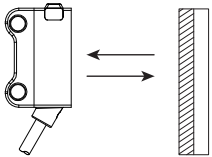
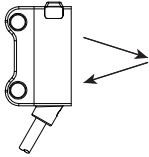

Detection method	Shape	Connection method	Detection distance	Model	
				NPN Output	PNP Output
Through-beam		Cable type	2m	Emitter PST-TM2DR Receiver PST-TM2DNOR	Emitter PST-TM2DR Receiver PST-TM2DPOR
		Cable type	2m	Emitter PST-TM2DR Receiver PST-TM2DNCR	Emitter PST-TM2DR Receiver PST-TM2DPCR
		Connector with cable type	2m	Emitter PST-TM2DR-F3 Receiver PST-TM2DNOR-F3	Emitter PST-TM2DR-F3 Receiver PST-TM2DPOR-F3
		Connector with cable type	2m	Emitter PST-TM2DR-F3 Receiver PST-TM2DNCR-F3	Emitter PST-TM2DR-F3 Receiver PST-TM2DPCR-F3
		Cable type	50cm	Emitter PST-TC50DR Receiver PST-TC50DNOR	Emitter PST-TC50DR Receiver PST-TC50DPOR
		Cable type	50cm	Emitter PST-TC50DR Receiver PST-TC50DNCR	Emitter PST-TC50DR Receiver PST-TC50DPCR
		Connector with cable type	50cm	Emitter PST-TC50DR-F3 Receiver PST-TC50DNOR-F3	Emitter PST-TC50DR-F3 Receiver PST-TC50DPOR-F3
		Connector with cable type	50cm	Emitter PST-TC50DR-F3 Receiver PST-TC50DNCR-F3	Emitter PST-TC50DR-F3 Receiver PST-TC50DPCR-F3
Retro reflection		Cable type	25cm	PST-DC25DNOR	PST-DC25DPOR
		Cable type	25cm	PST-DC25DNCR	PST-DC25DPCR
		Connector with cable type	25cm	PST-DC25DNOR-F3	PST-DC25DPOR-F3
		Connector with cable type	25cm	PST-DC25DNCR-F3	PST-DC25DPCR-F3
Convergent reflection		Cable type	2...25mm	PST-SR25DNOR	PST-SR25DPOR
		Cable type	2...25mm	PST-SR25DNCR	PST-SR25DPCR
		Connector with cable type	2...25mm	PST-SR25DNOR-F3	PST-SR25DPOR-F3
		Connector with cable type	2...25mm	PST-SR25DNCR-F3	PST-SR25DPCR-F3

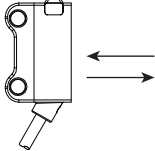
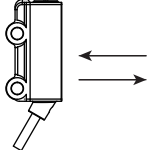
Guide Selection



Detection method	Shape	Connection method	Detection distance	Model	
				NPN Output	PNP Output
Background suppression		Cable type	8cm	PST-YC8DNOR	PST-YC8DPOR
		Cable type	8cm	PST-YC8DNCR	PST-YC8DPCR
		Connector with cable type	8cm	PST-YC8DNOR-F3	PST-YC8DPOR-F3
		Connector with cable type	8cm	PST-YC8DNCR-F3	PST-YC8DPCR-F3
		Cable type	10cm	PST-YC10DNOR	PST-YC10DPOR
		Cable type	10cm	PST-YC10DNCR	PST-YC10DPCR
		Connector with cable type	10cm	PST-YC10DNOR-F3	PST-YC10DPOR-F3
		Connector with cable type	10cm	PST-YC10DNCR-F3	PST-YC10DPCR-F3
		Cable type	15mm	PST-YR15DNOR	PST-YR15DPOR
		Cable type	15mm	PST-YR15DNCR	PST-YR15DPCR
		Connector with cable type	15mm	PST-YR15DNOR-F3	PST-YR15DPOR-F3
		Connector with cable type	15mm	PST-YR15DNCR-F3	PST-YR15DPCR-F3
		Cable type	30mm	PST-YR30DNOR	PST-YR30DPOR
		Cable type	30mm	PST-YR30DNCR	PST-YR30DPCR
		Connector with cable type	30mm	PST-YR30DNOR-F3	PST-YR30DPOR-F3
		Connector with cable type	30mm	PST-YR30DNCR-F3	PST-YR30DPCR-F3

Accessories(order separately)

Mounting bracket(Purchased seperately)

Applicable sensor	Shape	Model	Description
All part numbers		ZJP-11	Material:Carbon steel galvanized
All part numbers		ZJP-12	Material:Stainless steel
All part numbers		ZJP-13	Material:Stainless steel

Connection cable(Purchased seperately)

Applicable sensor	Shape	Model	Description
Sensors with cable+M8 connector		QE8-N3F2	M8 plug-in 3-pin female header
		QE8-N3G2	M8 plug-in 3-pin female header

Reflector(TD-11 is standard reflector for retro reflective sensors, other reflectors should be purchased seperately)

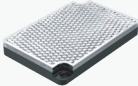
Applicable sensor	Shape	Model	Description
PST series		TD-09	Size:40*60mm
		TD-11	Size:13.8*23.4mm
		TD-12	Size:18*60mm

Specification-Through-beam

Type	Model			
NPN Cable type	PST-TM2DR PST-TM2DNOR	PST-TM2DR PST-TM2DNCR	PST-TC50DR PST-TC50DNCR	PST-TC50DR PST-TC50DNCR
NPN Connector with cable type	PST-TM2DR-F3 PST-TM2DNOR-F3	PST-TM2DR-F3 PST-TM2DNCR-F3	PST-TC50DR-F3 PST-TC50DNCR-F3	PST-TC50DR-F3 PST-TC50DNCR-F3
PNP Cable type	PST-TM2DR PST-TM2DPOR	PST-TM2DR PST-TM2DPCR	PST-TC50DR PST-TC50DPCR	PST-TC50DR PST-TC50DPCR
PNP Connector with cable type	PST-TM2DR-F3 PST-TM2DPOR-F3	PST-TM2DR-F3 PST-TM2DPCR-F3	PST-TC50DR-F3 PST-TC50DPCR-F3	PST-TC50DR-F3 PST-TC50DPCR-F3
Sensing distance	2m		50cm	
Standard target	φ 5mm above opaque objects		φ 2mm above opaque objects	
Min target	φ 3mm above opaque objects ^①		φ 1mm above opaque objects ^①	
Direction angle	Emitter:±1° Receiver:±4°		--	
Spot size	80mm@2m		4mm@50cm	
Consumption current	Emitter:≤10mA Receiver:≤15mA		Emitter:≤5mA Receiver:≤15mA	
Supply voltage	10...30VDC			
Load current	≤50mA			
Voltage drop	≤1.5V			
Light source	Red light (640nm)			
Protection circuit	Short circuit,reverse polarity,overload protection			
Indicator	Green:Power supply indicator,stability indication;Yellow:Output indication			
Response time	<1ms			
Anti ambient light	Sunlight interference ≤10,000 lux;Incandescent light interference ≤3,000 lux			
Operation temperature	-20...55 °C			
Storage temperature	-30... 70 °C			
Protection degree	IP67			
Certification	CE			
Shell material	ABS			
Lens	PMMA			
Weight	25g(2m Cable type),10g(0.2m Connector with cable type)			
Accessory	M3 Screws×2、Nut×2、 Operation manual			

Remark:

①The detection of the smallest detectable object can be achieved only under the appropriate sensitivity conditions

Signal redundancy(PST-TM2*)

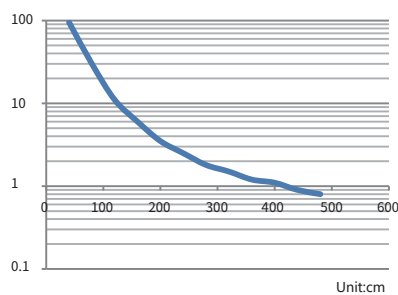

Action range(PST-TM2*)

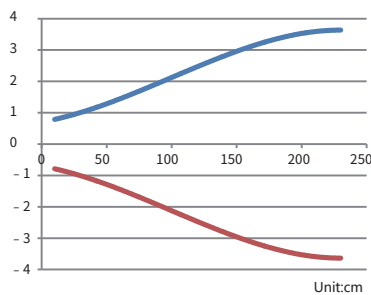

Spot size(PST-TC50*)

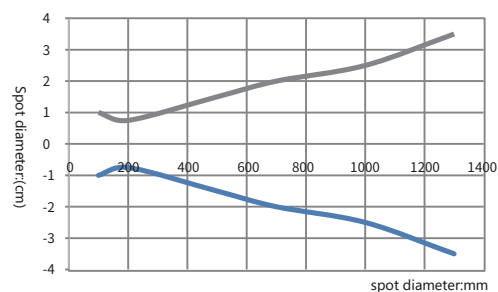

Specification-Retro reflection

Type	Model	
	NPN	PNP
Cable type	PST-DC25DNOR PST-DC25DNCR	PST-DC25DPOR PST-DC25DPCR
Connector with cable type	PST-DC25DNOR-F3 PST-DC25DNCR-F3	PST-DC25DPOR-F3 PST-DC25DPCR-F3
Sensing distance	25cm	
Standard target	φ 3mm opaque or translucent objects above	
Min target	φ 1mm opaque or translucent objects above	
Spot size	10mm@25cm	
Supply voltage	10...30VDC	
Consumption current	≤15mA	
Load current	≤50mA	
Voltage drop	≤1.5V	
Light source	Red light(640nm)	
Protection circuit	Short circuit,reverse polarity,overload protection	
Indicator	Green:Power supply indicator,stability indication;Yellow:Output indication	
Response time	<1ms	
Anti ambient light	Sunlight interference ≤10,000 lux;Incandescent light interference ≤3,000 lux	
Operation temperature	-20...55 °C	
Storage temperature	-30... 70 °C	
Protection degree	IP67	
Certification	CE	
Shell material	ABS	
Lens	PMMA	
Weight	25g(2m Cable type),10g(0.2m Connector with cable type)	
Accessory	M3 Screws×2、 Nut×2、 Reflector(TD-11)、 Operation manual	

Remark:The data is the detection result of LANBAO PST retro-reflection sensor with standard reflector TD-11

Signal redundancy

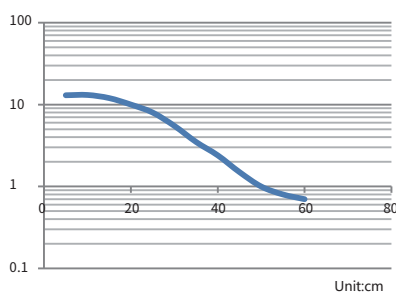

Action range

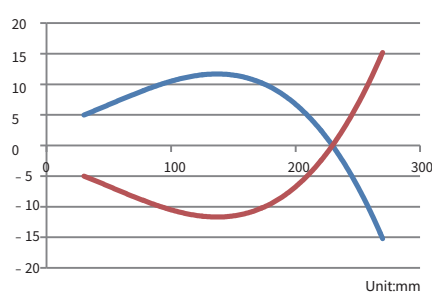

Detection distance

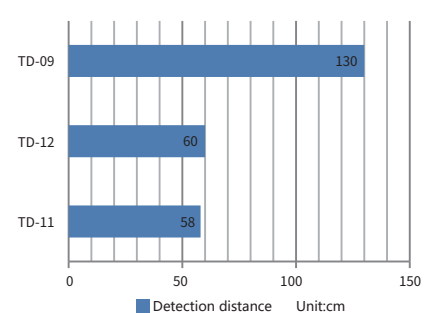

Specification-Convergent reflection

Type	Model	
	NPN	PNP
Cable type	PST-SR25DNOR PST-SR25DNCR	PST-SR25DPOR PST-SR25DPCR
Connector with cable type	PST-SR25DNOR-F3 PST-SR25DNCR-F3	PST-SR25DPOR-F3 PST-SR25DPCR-F3
Sensing distance	2...25mm	
Dead zone	<2mm	
Standard target	50*50mm white cards	
Min target	φ0.1mm copper wire(at the detection distance of 10mm)	
Return difference	<20%	
Supply voltage	10...30VDC	
Consumption current	≤15mA	
Load current	≤50mA	
Voltage drop	≤1.5V	
Light source	Red light(640nm)	
Protection circuit	Short circuit,reverse polarity,overload protection	
Indicator	Green:Power supply indicator,stability indication;Yellow:Output indication	
Response time	<1ms	
Anti ambient light	Sunlight interference ≤10,000 lux;Incandescent light interference ≤3,000 lux	
Operation temperature	-20...55 °C	
Storage temperature	-30...70 °C	
Protection degree	IP67	
Certification	CE	
Shell material	ABS	
Lens	PMMA	
Weight	25g(2m Cable type),10g(0.2m Connector with cable type)	
Accessory	M3 Screws×2、 Nut×2、 Operation manual	

Remark:Above data is measured based on 100mm*100mm 90% white card

Signal redundancy

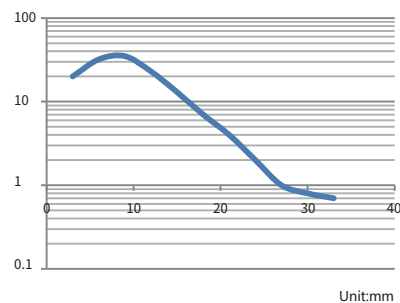

Action range

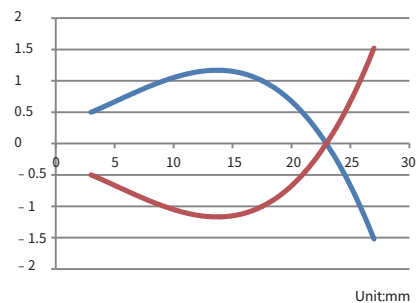

Detection distance

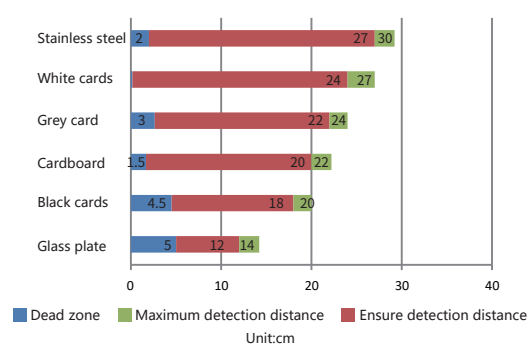

Specification-Background suppression

Type	Model	
	NPN	PNP
Cable type	PST-YC8DNOR PST-YC8DNCR	PST-YC8DPOR PST-YC8DPCR
Connector with cable type	PST-YC8DNOR-F3 PST-YC8DNCR-F3	PST-YC8DPOR-F3 PST-YC8DPCR-F3
Sensing distance	8cm	
Dead zone	<20mm	
Standard target	100*100mm white cards	
Min target	φ1mm above opaque objects	
Spot size	2mm@100mm	
Color sensitivity	>90%	
Return difference	<20%	
Supply voltage	10...30VDC	
Consumption current	≤15mA	
Load current	≤50mA	
Voltage drop	≤1.5V	
Light source	Red light(640nm)	
Protection circuit	Short circuit,reverse polarity,overload protection	
Indicator	Green:Power supply indicator,stability indication;Yellow:Output indication	
Response time	<1ms	
Anti ambient light	Sunlight interference ≤10,000 lux;Incandescent light interference ≤3,000 lux	
Operation temperature	-20...55 °C	
Storage temperature	-30... 70 °C	
Protection degree	IP67	
Certification	CE	
Shell material	ABS	
Lens	PMMA	
Weight	25g(2m Cable type),10g(0.2m Connector with cable type)	
Accessory	M3 Screws×2、 Nut×2、 Operation manual	

Remark:This is data measuring from 100mm*100mm 90% white card

Color sensitivity

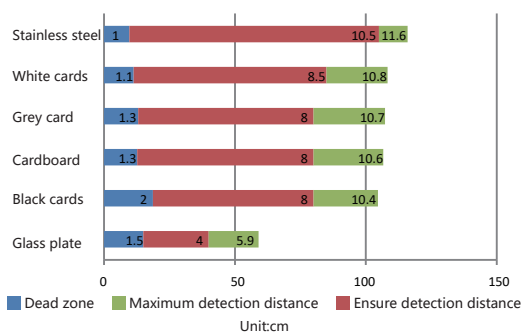

light spot size

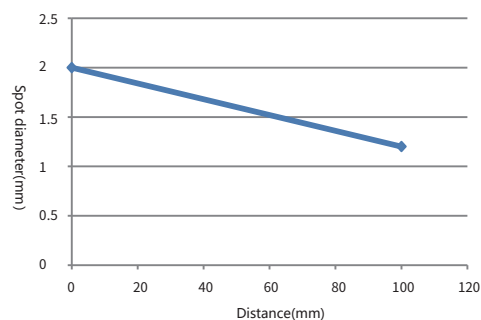

Specification-Background suppression

Type	Model						
	NPN		PNP		NPN		PNP
Cable type	PST-YC10DNOR PST-YC10DNCR	PST-YC10DPOR PST-YC10DPCR	PST-YR15DNOR PST-YR15DNCR	PST-YR15DPOR PST-YR15DPCR	PST-YR30DNOR PST-YR30DNCR	PST-YR30DPOR PST-YR30DPCR	
Connector with cable type	PST-YC10DNOR-F3 PST-YC10DNCR-F3	PST-YC10DPOR-F3 PST-YC10DPCR-F3	PST-YR15DNOR-F3 PST-YR15DNCR-F3	PST-YR15DPOR-F3 PST-YR15DPCR-F3	PST-YR30DNOR-F3 PST-YR30DNCR-F3	PST-YR30DPOR-F3 PST-YR30DPCR-F3	
Sensing distance	10cm		15mm		30mm		
Sensing range	0.5...12cm		4...18mm		1...36mm		
Dead zone	<0.5cm		<4mm		<1mm		
Standard target	100*100mm white cards						
Min target	φ1mm above opaque objects						
Spot size	3mm@100mm						
Color sensitivity	>85%						
Return difference	<20%						
Supply voltage	10...30VDC						
Consumption current	≤15mA						
Load current	≤50mA						
Voltage drop	≤1.5V						
Light source	Red light(680nm)						
Protection circuit	Short circuit,reverse polarity,overload protection						
Indicator	Green:Power supply indicator ;Yellow:Output indication						
Response time	<1ms						
Anti ambient light	Sunlight interference ≤10,000 lux;Incandescent light interference ≤3,000 lux						
Operation temperature	-20...55 °C						
Storage temperature	-30... 70 °C						
Protection degree	IP67						
Certification	CE						
Shell material	ABS						
Lens	PMMA						
Weight	25g(2m Cable type),10g(0.2m Connector with cable type)						
Accessory	M3 Screws×2、 Nut×2、 Operation manual						

Remark:This is data measuring from 100mm*100mm 90% white card

Color sensitivity(PST-YC10*)

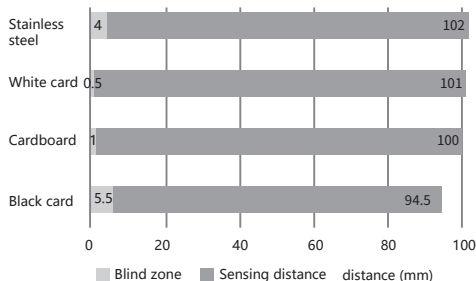

Color sensitivity(PST-YR15*)

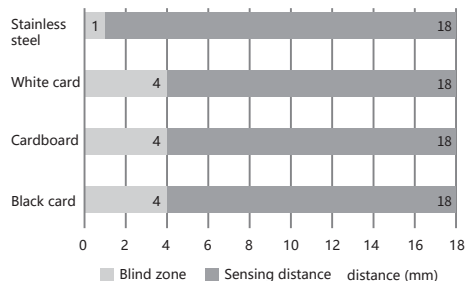

Color sensitivity(PST-YR30*)

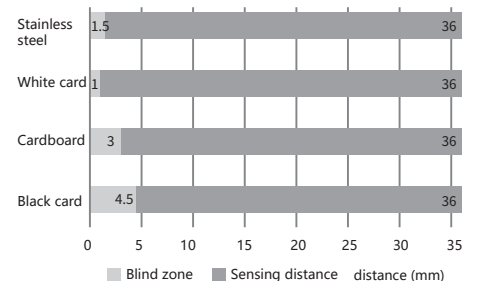

Distance-spot diameter

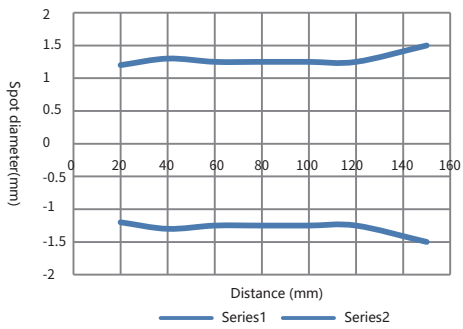

Distance- black-white difference

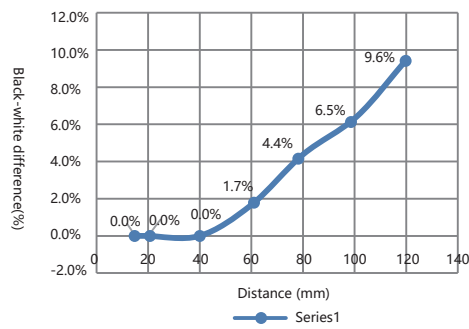

Dimension dwg

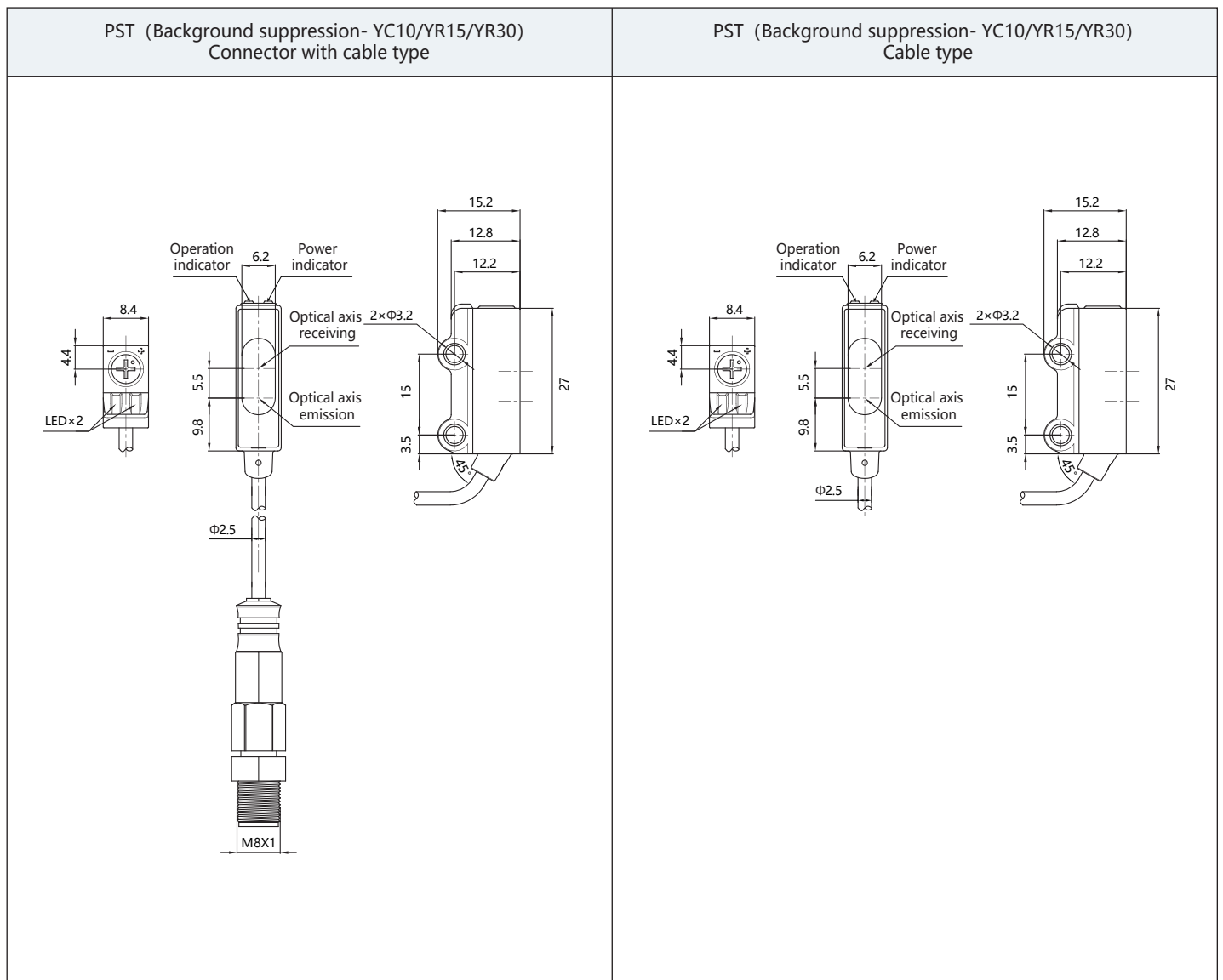

Dimension dwg

PST(Through-beam)Emitter-connector with cable type	PST(Through-beam)Receiver-connector with cable type	PST(Retroreflective, convergent reflection, background suppression reflection)-connector with cable type

PST(Through-beam)Emitter-cable type	PST(Through-beam)Receiver-cable type	PST(Retroreflective, convergent reflection, background suppression reflection)-cable type

Installation

Product Installation Diagram

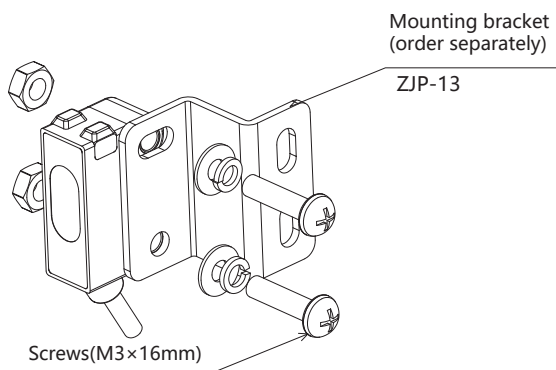
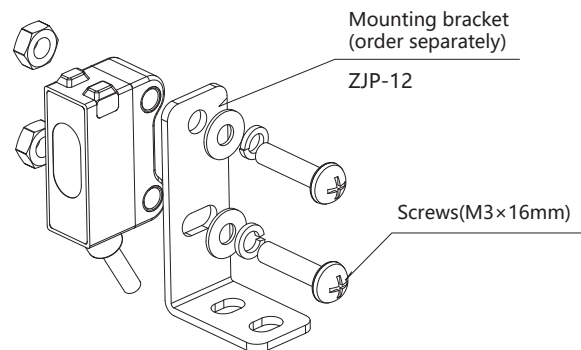
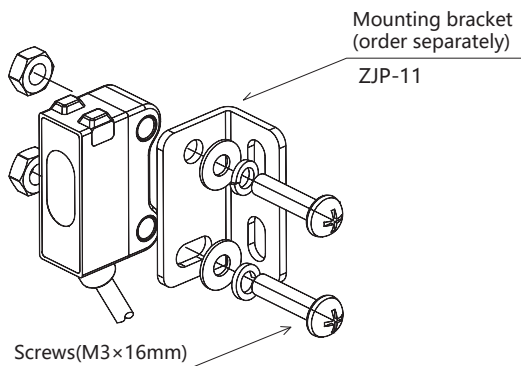

Remark:For mounting, please keep the tightening torque below 0.5N·m

Precautions

- Please make sure that the power supply voltage is within the rated voltage range before powering on
- The time from powering-on to normal detection is 100ms. Please make sure to use the sensor after 100ms of powering-on
- When using different power sources for the sensor and load, be sure to turn on the power of the sensor first
- When the sensor is not used, it is recommended to cut off the power on the load first, and then cut off the power of the sensor
- Do not subject the sensor to severe external forces (such as hammer hits, etc.) during installation, so as not to damage the sensor performance
- Avoid using thinner, alcohol or other organic solvents when cleaning the sensor

Installation precautions(Suitable for background suppression products)

- During installation, please make sensing face parallel to the sensing object (not inclined to the detection object, except for the shiny objects)

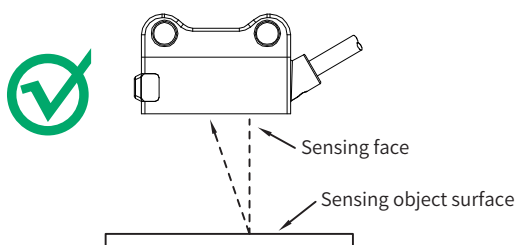

- To detect shiny objects (or shiny surfaces), please tilt the sensor by 5...10° as shown below

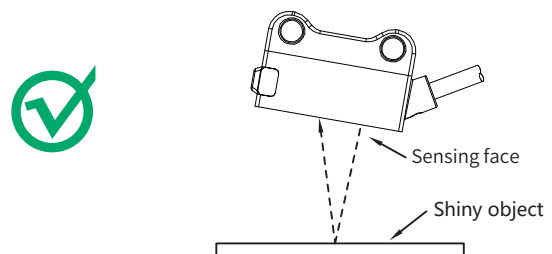

Installation precautions(Suitable for background suppression products)

- When sensor faces down to mirror body objects, the light emitted from sensing object is reflected to the mirror body and then returned to the sensor, which may sometimes cause unstable action. To avoid it, please install the sensor by tilting or keeping a certain distance from the sensor as shown in the right figure

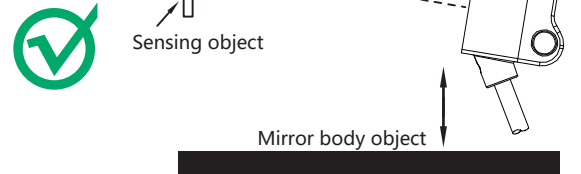

- Regarding to the installation direction, please pay attention to the movement direction of sensing object, and install it as shown below

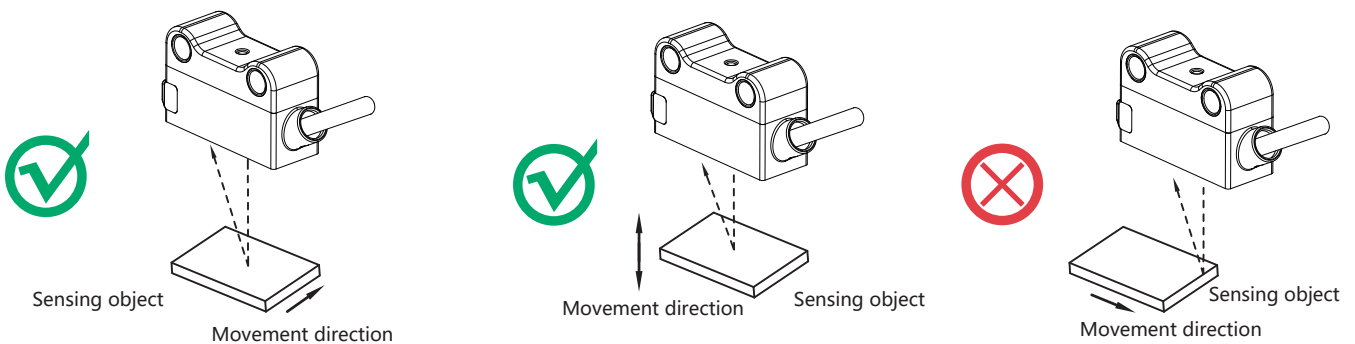

- When detecting objects with big color differences or different materials, please refer to the following methods for installation



Safety Warning

- Do not use in an environment with flammable, explosive or corrosive gases
- Do not use in an environment with oil or chemicals
- Do not use in a high humidity environment
- Do not use in direct sunlight
- Do not use in other environmental conditions that exceed the rated value
- Do not disassemble, service or modify this product without authorization

Scrap Treatment

- When the product is scrapped, please dispose of it as industrial waste