

Miniature photoelectric sensor PSV series



Feature description

- Small size, easy to install and use
- With 360° visible bright LED status indicator
- Superior anti-light interference, stable product performance
- Red light source for easy adjustment and alignment



Model specification

	Emitter		Receiver	
NPN NO	PSV-TC50DR	PSV-TC50DNOR	PNP NO	PSV-TC50DR
NPN NC	PSV-TC50DR	PSV-TC50DNCR	PNP NC	PSV-TC50DR

Specifications

Detection distance	50cm	Response time	<1ms
Standard test body	Φ2mm above opaque objects	Anti ambient light	Sunlight interference ≤10,000 lux
Direction angle	<2°		Incandescent light interference ≤3,000 lux
Light spot size	10*10cm@50cm	Operating temperature	-20...55 °C
Supply voltage	10...30VDC	Storage temperature	-30...70 °C
Consumption current	Emitter:≤10mA;Receiver:≤12mA	Protection degree	IP65
Load current	≤50mA	Certification	CE
Voltage drop	<1.5V	Shell material	PC+PBT
Light source	Red light(625nm)	Lens	PC
Protection circuit	Short circuit protection,Polarity protection	Weight	20g
	Overload protection,Zener protection	Accessory	Screws(M2×8mm)×2、Nut×2
Indicator	Green:power,stable indicator;Yellow:output indicator		

Dimension

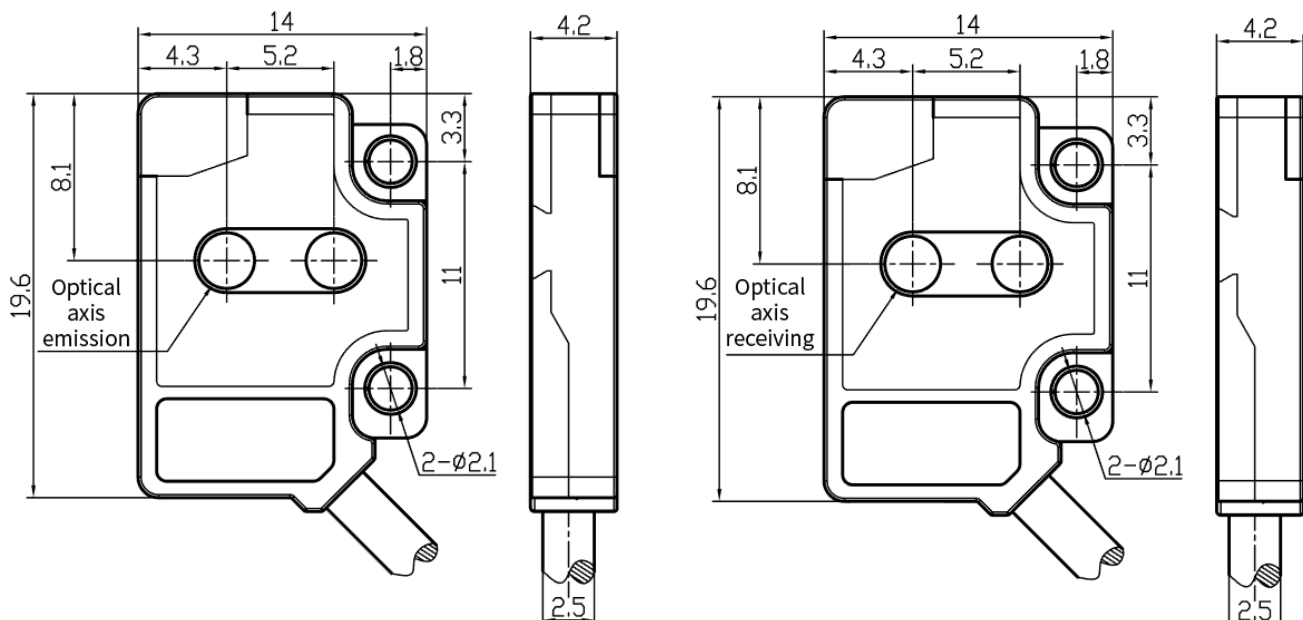

Wiring diagram

Receiver

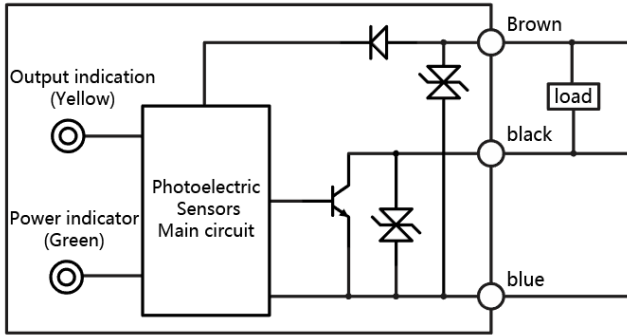

NPN

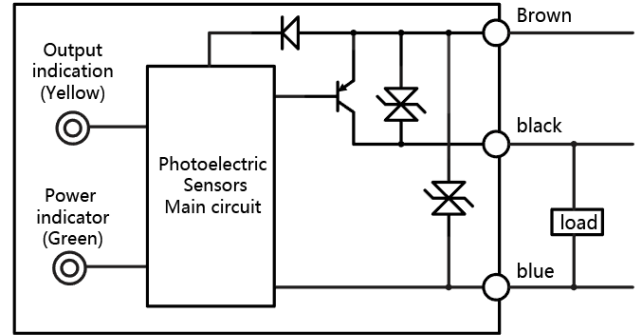

PNP

Emitter

