



## Main Feature

- 1 Pole to 4 Poles versions are available with switching current at 15 Amps (1 Pole) and 10 Amps (2-4 Poles).
- Printed Circuit Board Terminal, Solder Lug Terminal and Flanged Case are designed for direct panel mounting use.
- Low coil power consumption with high response time.
- High reliability and long life with better vibration and shock resistance.
- 1/3 Horse power on RET 2 Poles series are certified by UL.
- Touch Button and LED version are available for customer's selection.

## Contact Rating

Load Type	RET-1P	RET-2P	RET-3P	RET-4P
Rated Load (Resistive)	15A 250VAC	10A 250VAC	10A 250VAC	10A 250VAC
	15A 30VDC	10A 30VDC	10A 30VDC	10A 30VDC
Rated Carrying Current	15A	10A	10A	10A
Max. Allowable Voltage	AC 250V	AC 250V	AC 250V	AC 250V
	DC 110V	DC 110V	DC 110V	DC 110V
Max. Allowable Current	15A	10A	10A	10A
Max. Allowable Power Force	1,700VA	1,100VA	1,100VA	1,100VA
	360W	240W	240W	240W
Contact Material	Ag Alloy	Ag Alloy	Ag Alloy	Ag Alloy
Contact Form	SPDT, SPST	DPDT, DPST	3PDT, 3PST	4PDT, 4PST

## Application

Vending Machine, Cooking Appliances, Office Machine, Domestic Appliances, Control Equipment, etc.

## Performance (at Initial Value)

- Contact Resistance ..... 100 mΩ Max. @1A,6VDC
- Operate Time..... 25 mSec. Max.
- Release Time ..... 25 mSec. Max.
- Dielectric Strength :  
Between Coil & Contact ..... 1,500VAC at 50/60 Hz for one minute.  
Between Contacts ..... 1,000VAC at 50/60 Hz for one minute.
- Surge Strength ..... 3,000V (between Coil & Contact 1.2x50μSec.)
- Insulation Resistance ..... 100 MegaΩ Min. at 500VDC.
- Max. On/Off Switching :  
Electrical..... 6 Cycles per Minute.  
Mechanical ..... 300 Cycles per Minute.
- Temperature Range..... -25~55°C
- Humidity Range..... 45~85% RH.

- Coil Temperature Rise ..... 60°C Max.
- Vibration:  
Endurance ..... 10 to 55 Hz dual amplitude width 1.5mm.  
Error Operation..... 10 to 55 Hz dual amplitude width 1.5mm.
- Shock:  
Endurance ..... 1,000 m/S<sup>2</sup>.  
Error Operation..... 100 m/S<sup>2</sup>.
- Life Expectancy :  
Mechanical ..... 10<sup>7</sup> Operations at No Load condition.  
Electrical ..... 10<sup>5</sup> Operations at Rated Resistive Load.
- Weight ..... 1-2P :About 35 g.  
3P :About 53.2g.  
4P :About 66.5g.

## Safety Standard & Its File Number

- C-UL (1-pole & 2-pole). ..... E141060
- CQC.....07001018730(For RET-1P/2P)

## Coil Specification (at 20°C)

Coil Sensitivity	Coil Voltage Code	Nominal Voltage (VAC/VDC)	Nominal Current (mA)		Coil Resistance ( $\Omega \pm 10\%$ )	Power Consumption		Pull-In Voltage (VDC)	Drop-Out Voltage (VDC)	Max.Allowable Voltage (VDC)
			50 Hz	60 Hz		50Hz	60Hz			
RET 1-P & 2-P AC Coil	01	6	282.7	214.3	10	1.7VA	1.29VA	80% Maximum	30% Minimum	110%
	02	12	106.2	94.9	40	1.27VA	1.14VA			
	03	24	52.8	45.5	160	1.27VA	1.09VA			
	04	48	23.7	20.0	600	1.1VA	0.96VA			
	05	110	12.5	10.3	3,400	1.37VA	1.13VA			
	06	120	16.8	14.3	3,400	2.01VA	1.72VA			
	07	220	6.2	5.1	13,600	1.36VA	1.12VA			
	08	240	7.2	5.9	13,600	1.74VA	1.41VA			
	09	230	7.0	5.7	13,600	1.61VA	1.31VA			
RET 3-P AC Coil	01	6	310	270	6.7	Abt. 1.6 to 2.0VA (60 Hz)	80% Maximum	30% Minimum	110%	
	02	12	159	134	24					
	03	24	80	67	100					
	04	48	38	33	410					
	05	110	16	13.7	2,300					
	06	120	15.4	13.2	2,300					
	07/08	220/240	10	8.5	8,650					
RET 4-P AC Coil	01	6	386	330	5	Abt. 1.95 to 2.5 VA (60 Hz)	80% Maximum	30% Minimum	110%	
	02	12	199	170	20					
	03	24	93.6	80	78					
	04	48	46.8	40	350					
	05	110	25.5	21.8	1,600					
	06	120	24.5	21	1,600					
	07/08	220/240	13.1	11.2	6,700					
RET 1-P & 2-P DC Coil	01	6	150		40	Abt. 0.9 W	80% Maximum	10% Minimum	110%	
	02	12	75		160					
	03	24	36.9		650					
	04	48	18.5		2,600					
	05	110	10		11,000					
	06	120	10		11,000					
	10	60	15		4,000					
RET 3-P DC Coil	01	6	234		25.7	Abt. 1.4 W	80% Maximum	10% Minimum	110%	
	02	12	112		107					
	03	24	58.6		410					
	04	48	28.2		1,700					
	05	110	13		8,500					
	06	120	14.1		8,500					
RET 4-P DC Coil	01	6	240		25	Abt. 1.5 W	80% Maximum	10% Minimum	110%	
	02	12	120		100					
	03	24	69		350					
	04	48	30		1,600					
	05	110	15.9		6,900					
	06	120	17.4		6,900					

## Ordering Information

RET - 2 - 01 D M P F L T	<b>Touch Button:</b>	Nil: Standard Relay T: With Touch Button Selection
	<b>LED:</b>	Nil: Standard Relay L: With LED Selection (Use Polarity LED) Z: Coil Parallel with Diode & the Positive Pole " + " On #8(RET-1P,RET-2P) 、 #11(RET-3P) 、 #14(RET-4P) Y: Coil Parallel with Diode & the Negative Pole " - " On #8(RET-1P,RET-2P) 、 #11(RET-3P) 、 #14(RET-4P) X : Coil Parallel with Diode + LED & the Positive Pole " + " On #8(RET-1P,RET-2P) 、 #11(RET-3P) 、 #14(RET-4P) V : Coil Parallel with Diode + LED & the Negative Pole " - " On #8(RET-1P,RET-2P) 、 #11(RET-3P) 、 #14(RET-4P)
	<b>Case Type:</b>	Nil: Standard Square Shape F: Flanged Case
	<b>Terminal Type:</b>	Nil: Solder Lug Terminal P: PC Board Terminal
	<b>Contact Form:</b>	Nil: Form C M: Form A B: Form B
	<b>Coil Type:</b>	D: DC Coil A: AC Coil
	<b>Coil Code:</b>	01: 6V, 02: 12V, 03: 24V, 04: 48V, 05: 110V, 06: 120V, 07: 220V, 08: 240V, 09: 230V, 10: 60V
	<b>Number of Pole:</b>	1: 1 Pole 2: 2 Poles 3: 3 Poles 4: 4 Poles
	<b>Type:</b>	RET

## Classification

Model	RET							
	AC Coil				DC Coil			
Coil Type								
Number Of Poles	1C / 1A / 1B	2C / 2A / 2B	3C / 3A / 3B	4C / 4A / 4B	1C / 1A / 1B	2C / 2A / 2B	3C / 3A / 3B	4C / 4A / 4B
Contact Form	RET-1/2□□A/AM/AB		RET-3/4□□A/AM/AB		RET-1/2□□A/AM/AB		RET-3/4□□A/AM/AB	
Terminal Type	RET-1/2□□A/AM/AB RET-1/2□□AP/AMP/ABP		RET-3/4□□A/AM/AB RET-3/4□□AP/AMP/ABP		RET-1/2□□A/AM/AB RET-1/2□□AP/AMP/ABP		RET-3/4□□A/AM/AB RET-3/4□□AP/AMP/ABP	
Case Type	RET-1/2□□A/AM/AB RET-1/2□□AF/AMF/ABF		NIL		RET-1/2□□D/DM/DB RET-1/2□□DF/DMF/DBF		NIL	
LED	RET-1/2□□AL/AML/ABL RET-1/2□□APL/AMPL/ABPL RET-1/2□□AFL/AMFL/ABFL		NIL		RET-1/2□□DL/DML/DBL RET-1/2□□DPL/DMPL/BPL RET-1/2□□DFL/DMFL/DBFL		NIL	
Touch Button	RET-1/2□□AT/AMT/ABT RET-1/2/□□ APLT/AMPLT/ABPLT RET-1/2/□□ALT/AMLT/ABLT RET-1/2/□□ AFLT/AMFLT/ABFLT		NIL		RET-1/2□□DT/DMT/DBT RET-1/2/□□ DPLT/DMPLT/DBPLT RET-1/2/□□DLT/DMLT/DBLT RET-1/2/□□ DFLT/DMFLT/DBFLT		NIL	

Dimension ( $\leq 5\text{mm} \pm 0.2\text{mm}$ ,  $> 5\text{mm} \pm 0.3\text{mm}$ , the tolerance of PCB thru hole:  $+0.1\text{mm}$ )

RET-1-P

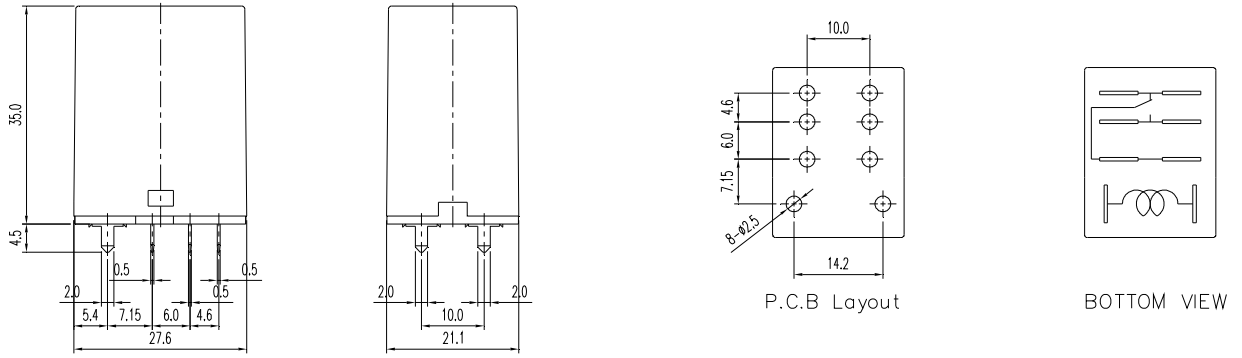

RET-1

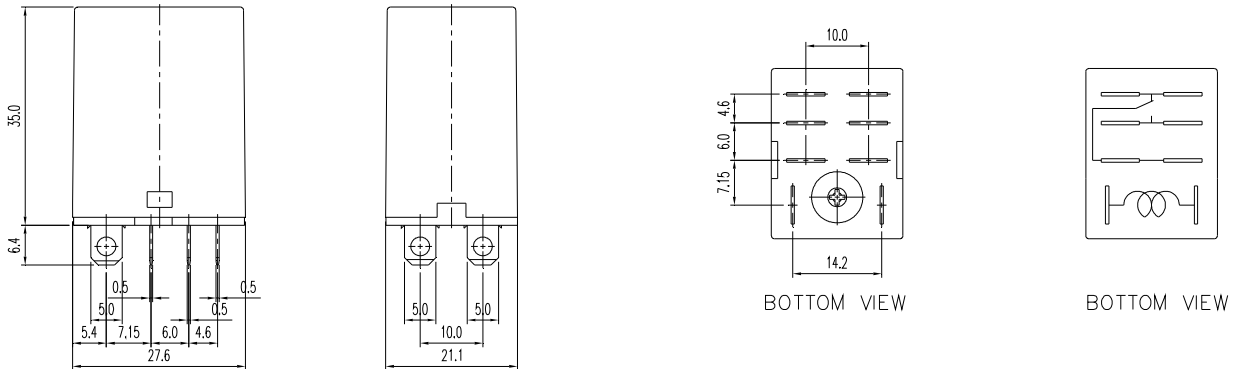

RET-1-F

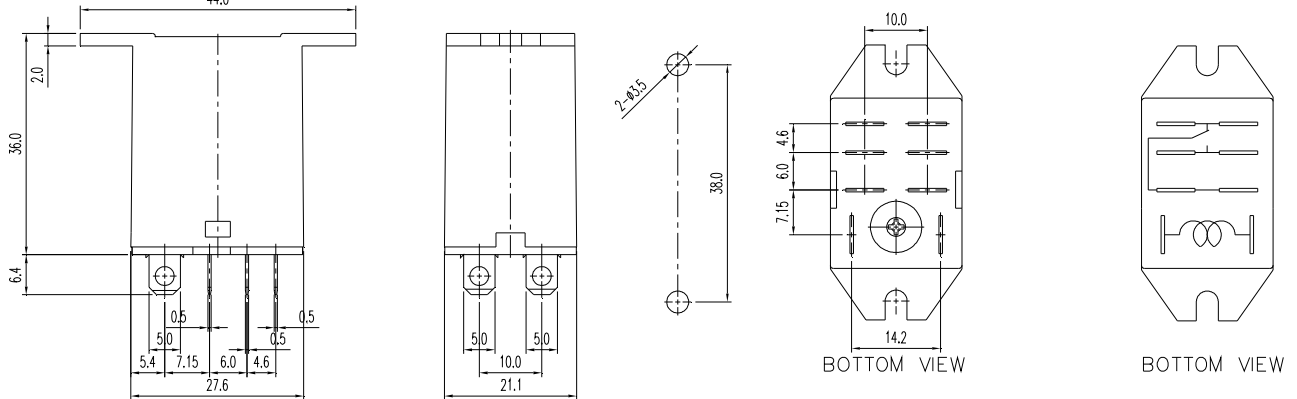

RET-2-P

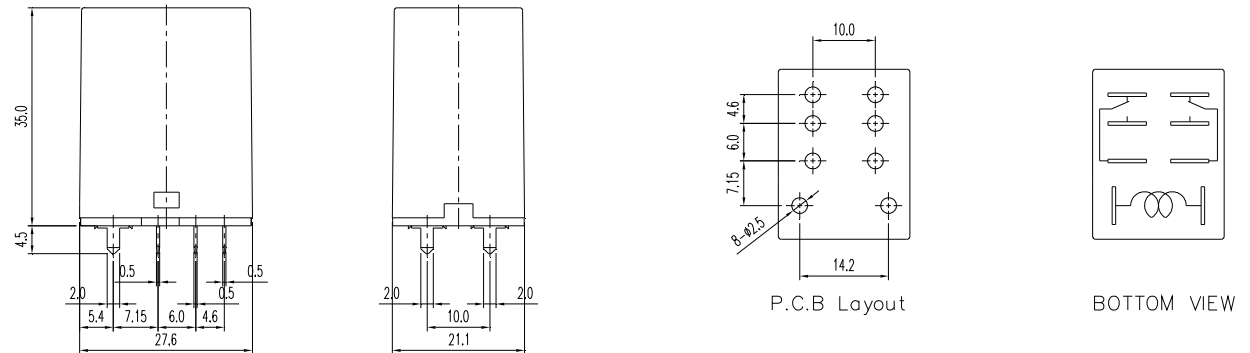

RET-2

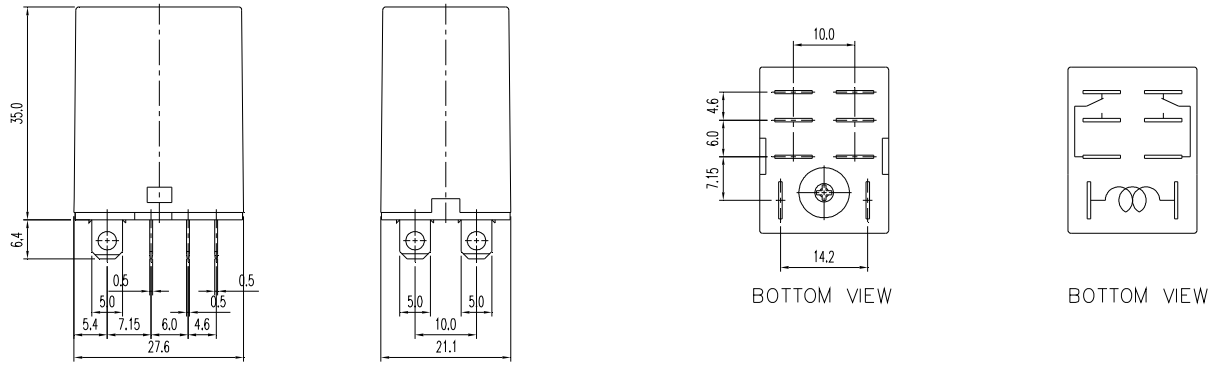

RET-2-F

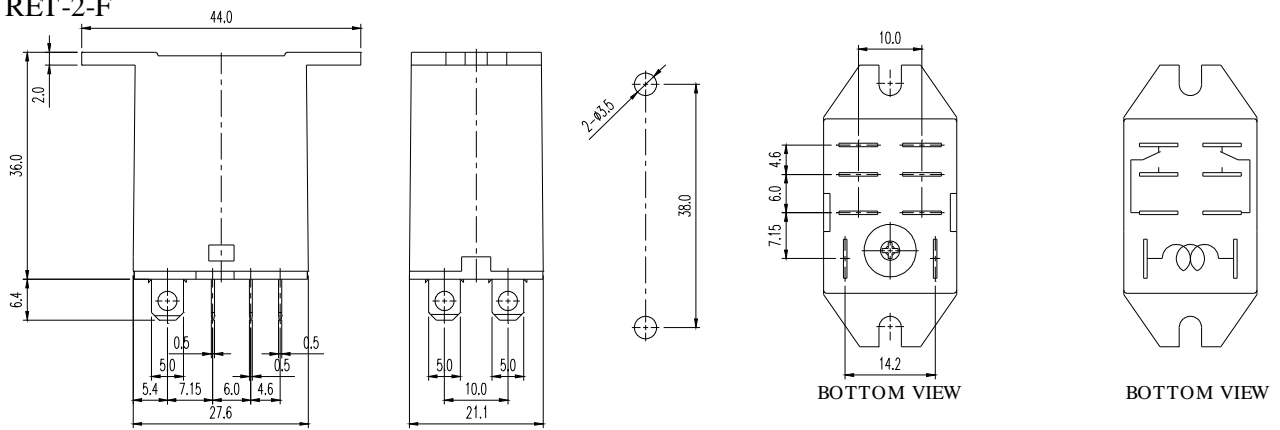

RET-3

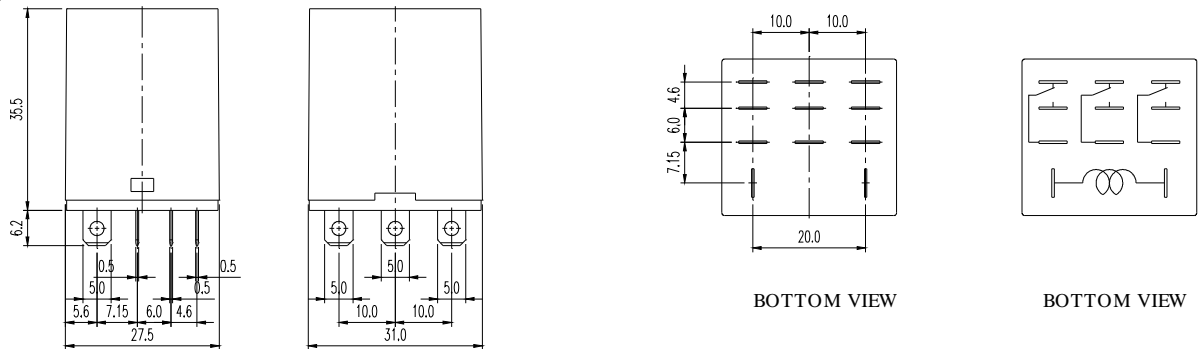

RET-4

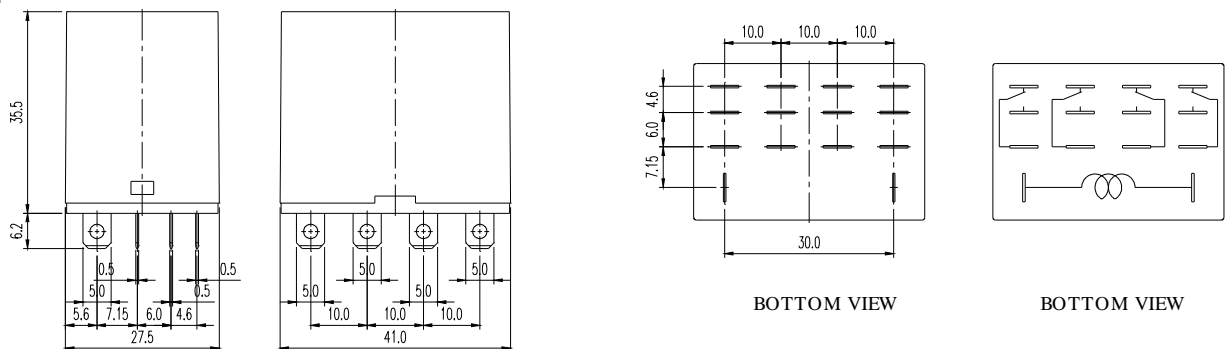

## Accessories & Sockets

### RET-1P/2P

- PTF-08A .....See Page 174
- PTF-08AE .....See Page 174
- PT-08 .....See Page 179
- PT-08-0 .....See Page 179

### RET-4P

- PTF-14A.....See Page 174
- PTF-14AE..... See Page 174

## Wiring diagrams (Bottom view)

RET-1P					
RET-1□D□□□□L□	RET-1□D□□□□Z□	RET-1□D□□□□Y□	RET-1□D□□□□X□	RET-1□D□□□□V□	AC Coil Model With LED
RET-2P					
RET-2□D□□□□L□	RET-2□D□□□□Z□	RET-2□D□□□□Y□	RET-2□D□□□□X□	RET-2□D□□□□V□	AC Coil Model With LED
RET-3P					
RET-3□D□□□□L□	RET-3□D□□□□Z□	RET-3□D□□□□Y□	RET-3□D□□□□X□	RET-3□D□□□□V□	AC Coil Model With LED
RET-4P					
RET-4□D□□□□L□	RET-4□D□□□□Z□	RET-4□D□□□□Y□	RET-4□D□□□□X□	RET-4□D□□□□V□	AC Coil Model With LED